

MAYOR
Timothy Woolley

Cynthia A. Bower
CLERK

Nicone Dragone Sr.
TREASURER

CITY OF TAYLOR



*23555 Goddard Road
Taylor, MI 48180
(734) 287 6550
www.cityoftaylor.com*

COUNCIL
Charley Johnson
CHAIRMAN

Ron Thiede
CHAIR PRO-TEM

*Christian Armstrong
Chris Clark
William Patts
Gerald P. Thomas
Dan Wallace*

The Regular Council Meeting of the Taylor City Council will be held on Tuesday February 03, 2026 in the Taylor Municipal Building at 23555 Goddard Rd., Taylor, MI to begin promptly at 6:30 PM

AGENDA

1. Call to order
2. Pledge of Allegiance
3. Roll Call
4. **AGENDA AND MINUTES**
 - 4.1 Motion to approve the Agenda.
 - 4.2 Motion to approve the acceptance of the minutes of the meeting held on January 20, 2026 and dispense with oral reading.
[2026_01_20 Final.pdf](#)
5. **MAYOR COMMUNICATIONS**
 - 5.1 Motion to approve the re-appointments of Ron Moran, Timothy Schramm and Rich Todd to the Tax Increment Finance Authority (TIFA) and Brownfield Re-Development Authority (BRDA) for a four (4) year term to expire on February 3, 2030.
 - 5.2 Motion to approve the new appointment of Britany Carmona to the Library Board for a five (5) year term to expire on February 3, 2031.
6. **REGULAR AGENDA**
 - 6.1 Motion to receive & file Fish and Loaves Presentation.
 - 6.2 Motion to receive & file Presentation for the Cool School PlungeSTER for Special Olympics Michigan to be held on March 5, 2026.
[Special Olympics Pres.pdf](#)
 - 6.3 Motion to approve City of Taylor budget amendment 2026-004 dated February 3, 2026.
[Budget Amendment 2026-004.pdf](#)

- 6.4 Motion to approve Magnet Forensics, preferred vendor, for the purchase of Magnet AXIOM software and specialized training for an amount not to exceed \$12,994, funded through General Fund - Police Contractual Services and Police Training.
[Magnet Axiom Software Quote.pdf](#)
[Magnet Forensics Training Quote.pdf](#)
[Cellebrite Quote.pdf](#)
[Passware quote.pdf](#)
- 6.5 Motion to approve accepting the MCOLES Public Safety Academy Assistance Grant to cover academy tuition and salary reimbursements of one (1) sponsored Police Officer Candidate from the Eligibility List, attending the Wayne County Regional Police Training Academy.
- 6.6 Motion to receive & file 0 % interest deferred loan for project #2025-10 for work performed by Optimum Contracting Solutions, qualified low quote, for Emergency HVAC Replacement in the amount of \$11,125. Funded through the Community Development Block Grant Home Rehabilitation account. Not to exceed program limits.
[Invoice for Optimum Contraction 1.15.2026.pdf](#)
[Bid Tabulation for 16046 Allen Road project.pdf](#)
- 6.7 Motion to amend CCR#12.537-25 to increase authority to Detroit Salt, current vendor, for an amount not to exceed \$40,000. Funded through General Fund-Department of Public Works-Operating Supplies Salt.
[CCR#12-537-25](#)
- 6.8 Motion to amend CCR #7.289-25 to increase authority to Ecoverse to \$15,000, funded through Compost Equipment Repair and Maintenance.
[CCR Minutes 7/1/25](#)
[Approved vendors.pdf](#)
- 6.9 Motion to approve Wolverine Freightliner and Truck & Trailer Specialties to purchase one (1) Freightliner 108SD Chassis with dump truck equipment, for an amount not to exceed \$238,493. Funded through DPW Vehicle Account.
[Taylor SA UTS RFQ Quote 011326 \(1\).pdf](#)
[Taylor 108SD PLUS SA Price Page 2027 \(2\).pdf](#)
[Wolverine_Executed_Agreement__1_.pdf](#)
[Taylor SA 108SD Plus Plow Specs 2027 \(1\) \(1\).pdf](#)
[Dump Truck Purchasing approval.pdf](#)
- 6.10 Motion to approve ENTA Supply for the annual Sensus Flexnet hosting fees in an amount not to exceed \$39,400. Funded through Water Billing Contractual Services.
[etna_9560_20260124_31682785_14867935104.pdf](#)
[Sole Source Document.pdf](#)
- 6.11 Motion to approve the Mayor to sign the attached lease agreement between the City of Taylor and Rosecrans Picture Perfect.
[Rosecrans Picture Perfect Lease 1-13-26 \(2\).pdf](#)
- 6.12 Motion to amend CCR#1.13-26 for International Controls & Equipment, sole source, to perform additional necessary repairs and required work on the Pine and Birch Street security

gates in an amount not to exceed \$20,000, funded through TBA Capital Outlay.

[International Controls & Equipment.pdf](#)

[International_Controls__Equipment_Sole_Source \(1\).pdf](#)

6.13 Motion to approve

Signs By Crannie, qualified low bid, to provide signage and installation of signs at Lange Park, for an amount of \$51,441, plus a 10% contingency, for an amount not to exceed \$56,586. Funded through Capital Outlay ARPA Grant.

[scan \(31\).pdf](#)

[Signs By Crannie Lange Park Proposal.pdf](#)

[Signs By Crannie 1.pdf](#)

[Signs By Crannie 2.pdf](#)

[Signs By Crannie 3.pdf](#)

[Signs By Crannie 4.pdf](#)

[Signs By Crannie 5.pdf](#)

[Signs By Crannie 6.pdf](#)

[Signs By Crannie 7.pdf](#)

[Lange Park Purchasing Approval.pdf](#)

6.14 Motion to approve removal of special assessment from the Winter 2025 tax bill in the amount of \$3,487 and delinquent water charges in the amount of \$6,465 of parcel #075-01-0139-300.

[Special_Removal15163BeechDaly.pdf](#)

6.15 Motion to approve solicitation request from Knights of Columbus All Saints Council #4872 to hold a Tootsie Roll Drive on March 27-29, 2026.

[Knights of Columbus Solicitation Request 2026.pdf](#)

7. **OPEN BUSINESS**

8. **ADJOURNMENT**

Motion By: Gerald Thomas **Supported By:** Dan Wallace
Ayes: Charley Johnson, Chris Clark, Dan Wallace, William Patts, Ron Thiede, Christian Armstrong, Gerald Thomas
Nays: None
Resolved: To approve the re-appointment of Barbara Kotarsky to the Aging Commission for a two (2) year term to expire on January 20, 2028.

Unanimously carried
CCR #: 1.22-26

Motion By: Ron Thiede **Supported By:** Christian Armstrong
Ayes: Charley Johnson, Chris Clark, Dan Wallace, William Patts, Ron Thiede, Christian Armstrong, Gerald Thomas
Nays: None
Resolved: To approve the re-appointment of Sean McGuckin to the Downtown Development Authority (DDA) for a four (4) year term to expire on January 20, 2030.

Unanimously carried
CCR #: 1.23-26

Motion By: William Patts **Supported By:** Dan Wallace
Ayes: Charley Johnson, Chris Clark, Dan Wallace, William Patts, Ron Thiede, Christian Armstrong, Gerald Thomas
Nays: None
Resolved: To approve the new alternate appointment of Gorden Daisy to the Zoning Board of Appeals for a three (3) year term to expire on January 20, 2029.

Unanimously carried
CCR #: 1.24-26

Motion By: Gerald Thomas **Supported By:** Christian Armstrong
Ayes: Charley Johnson, Chris Clark, Dan Wallace, William Patts, Ron Thiede, Christian Armstrong, Gerald Thomas
Nays: None
Resolved: To approve the new appointment of Anthony Sautter to the Tax Increment Finance Authority (TIFA) and Brownfield Redevelopment Authority (BRDA) for a four (4) year term to expire on January 20, 2030.

Unanimously carried
CCR #: 1.25-26

Motion By: Dan Wallace **Supported By:** Chris Clark
Ayes: Charley Johnson, Chris Clark, Dan Wallace, William Patts, Ron Thiede, Christian Armstrong, Gerald Thomas
Nays: None
Resolved: To receive & file the December 2025 Budget Performance Report.

Unanimously carried
CCR #: 1.26-26

Motion By: Dan Wallace **Supported By:** Chris Clark
Ayes: Charley Johnson, Chris Clark, Dan Wallace, William Patts, Ron Thiede, Christian Armstrong, Gerald Thomas

Nays: None

Resolved: To receive & file the December 2025 Paid Invoice Report.

Unanimously carried

CCR #: 1.27-26

Motion By: Dan Wallace **Supported By:** Chris Clark
Ayes: Charley Johnson, Chris Clark, Dan Wallace, William Patts, Ron Thiede, Christian Armstrong, Gerald Thomas

Nays: None

Resolved: To approve Emergency Training Solutions for required annual training of ACLS and BLS Support in an amount not to exceed \$8,100. Funded through General Fund- Fire, Training and Transport Account.

Unanimously carried

CCR #: 1.28-26

Motion By: Dan Wallace **Supported By:** Chris Clark
Ayes: Charley Johnson, Chris Clark, Dan Wallace, William Patts, Ron Thiede, Christian Armstrong, Gerald Thomas

Nays: None

Resolved: To approve One (1) member of the fire department to attend the Fire Inspector Training for an amount not to exceed \$1,067. Funded through General Fund-Training and Transport account.

Unanimously carried

CCR #: 1.29-26

Motion By: Dan Wallace **Supported By:** Chris Clark
Ayes: Charley Johnson, Chris Clark, Dan Wallace, William Patts, Ron Thiede, Christian Armstrong, Gerald Thomas

Nays: None

Resolved: To receive & file the Planning Commission's annual report for 2023/2024.

Unanimously carried

CCR #: 1.30-26

Motion By: Dan Wallace **Supported By:** Chris Clark
Ayes: Charley Johnson, Chris Clark, Dan Wallace, William Patts, Ron Thiede, Christian Armstrong, Gerald Thomas

Nays: None

Resolved: To approve payment to MISS DIG 811 for the annual membership/maintenance fee, for an amount not to exceed \$17,682. Funded through Water Supply System Fund, Contractual Services- Miss Dig.

Unanimously carried

CCR #: 1.31-26

Motion By: Dan Wallace **Supported By:** Chris Clark
Ayes: Charley Johnson, Chris Clark, Dan Wallace, William Patts, Ron Thiede, Christian Armstrong, Gerald Thomas
Nays: None
Resolved: To approve the Mayor to sign the contract with Elliott's Amusements for Carnival Services at the 2026 Taylor Summer Festival.

Unanimously carried
CCR #: 1.32-26

Motion By: Gerald Thomas **Supported By:** Dan Wallace
Ayes: Charley Johnson, Chris Clark, Dan Wallace, William Patts, Ron Thiede, Christian Armstrong, Gerald Thomas
Nays: None
Resolved: To receive & file the June 30, 2025 city financial audit as presented by the auditors, Plante Moran PLLC.

Unanimously carried
CCR #: 1.33-26

Motion By: Chris Armstrong **Supported By:** William Patts
Ayes: Charley Johnson, Chris Clark, Dan Wallace, William Patts, Ron Thiede, Christian Armstrong, Gerald Thomas
Nays: None
Resolved: To approve payment to Center Mass, Inc., for providing the Firearms Instructor School training to three (3) Police Officers, in an amount not to exceed \$4,077, funded through MCOLES Act 302 Police Training Fund.

Unanimously carried
CCR #: 1.34-26

Motion By: William Patts **Supported By:** Dan Wallace
Ayes: Charley Johnson, Chris Clark, Dan Wallace, William Patts, Ron Thiede, Christian Armstrong, Gerald Thomas
Nays: None
Resolved: To approve a three (3) year renewal of vehicle mounted pursuit reduction technology, to include additional units, from Starchase, current sole source vendor, for an amount not to exceed \$86,785, funded through Federal Forfeiture - Treasury Capital Outlay.

Unanimously carried
CCR #: 1.35-26

Motion By: William Patts **Supported By:** Chris Clark
Ayes: Charley Johnson, Chris Clark, Dan Wallace, William Patts, Ron Thiede, Christian Armstrong, Gerald Thomas
Nays: None
Resolved: To approve authorizing the Mayor to sign the Purchase Agreement on behalf of the City of Taylor for the sale of Parcel ID number 60-088-01-0020-001 for the amount of \$1,200, plus closing costs. Proceeds go to the General Fund.

Unanimously carried
CCR #: 1.36-26

Motion By: Gerald Thomas **Supported By:** Ron Thiede
Ayes: Charley Johnson, Chris Clark, Dan Wallace, William Patts, Ron Thiede, Christian Armstrong, Gerald Thomas
Nays: None
Resolved: To approve Wolverine Freightliner and Truck & Trailer Specialties, Sourcewell Bid, to purchase one (1) Freightliner MT55 Chassis with Utilimaster Walk-in Van Body, for an amount not to exceed \$295,154. Funded through Water Department Capital Outlay Account.

Interested Parties; Resident

Unanimously carried
CCR #: 1.37-26

Motion By: William Patts **Supported By:** Dan Wallace
Ayes: Charley Johnson, Chris Clark, Dan Wallace, William Patts, Ron Thiede, Christian Armstrong, Gerald Thomas
Nays: None
Resolved: To amend CCR# 5.210-25 for Fairfax Electrical, low bid, to provide electrical services at Lange Park per the attached document for an amount not to exceed \$50,000. Funded through Capital Outlay ARPA Grant.

Unanimously carried
CCR #: 1.38-26

Motion By: Gerald Thomas **Supported By:** Ron Thiede
Ayes: Charley Johnson, Chris Clark, Dan Wallace, William Patts, Ron Thiede, Christian Armstrong, Gerald Thomas
Nays: None
Resolved: To approve Community Publishing and Marketing for publication and mailing of the Taylor Today Magazine, seven (7) times per year. This agreement is a three (3) year term, year 2026 for a cost not to exceed \$40,950, year 2027 for a cost not to exceed \$43,050 and year 2028 for a cost not to exceed \$45,150. Funding paid through various accounts: Police, Water, Sewer, Building and General Fund.

Interested Parties: C. Patts

Unanimously carried
CCR #: 1.39-26

Motion By: Chris Clark **Supported By:** Chris Armstrong
Ayes: Charley Johnson, Chris Clark, Dan Wallace, William Patts, Ron Thiede, Christian Armstrong, Gerald Thomas
Nays: None
Resolved: To approve extending the due date for payment on Winter 2025 taxes to February 28, 2026.

Unanimously carried
CCR #: 1.40-26

Motion By: Gerald Thomas **Supported By:** Dan Wallace
Ayes: Charley Johnson, Dan Wallace, Ron Thiede, Christian Armstrong, Gerald Thomas
Nays: Chris Clark, William Patts
Resolved: To receive & file the 2025 Compensation Commission determination for the following Elected Officials; Mayor, Clerk, Treasurer, Council Chair, Council Chair Pro-Tem and Council Members.

Roll Call Vote

5 – 2 Motion carried
CCR #: 1.41-26

Motion By: Gerald Thomas **Supported By:** Christian Armstrong
Ayes: Charley Johnson, Chris Clark, Dan Wallace, William Patts, Ron Thiede, Christian Armstrong, Gerald Thomas
Nays: None
Resolved: To adopt a twelve (12) month moratorium on the acceptance and processing of any applications, permits, and/or site plans for any data centers or similar data storage facilities in the City of Taylor for a period of twelve (12) months from January 20, 2026, at 11:59 P.M. until January 20, 2027, at 11:59 P.M..

Interested Parties: T. Katinski

Unanimously carried
CCR #: 1.42-26

Motion By: Christian Armstrong **Supported By:** Chris Clark
Ayes: Charley Johnson, Chris Clark, Dan Wallace, William Patts, Ron Thiede, Christian Armstrong, Gerald Thomas
Nays: None
Resolved: To approve adjournment at 7:40 p.m.

Unanimously carried
CCR #: 1.43-26

Charley Johnson, Chairman

Cynthia A. Bower, City Clerk

What Is Unified Special Olympics?

Unified Special Olympics brings students with and without disabilities together through sports, teamwork, and shared activities. The goal is simple: *inclusion, connection, and friendship.*





Why It Matters in Our Schools

Each school in our district receives funding to support Unified Special Olympics activities. This allows us to:

- Purchase equipment and materials
- Create opportunities for our POHI and self-contained special education students
- Partner them with general education students
- Build meaningful friendships and an inclusive school culture

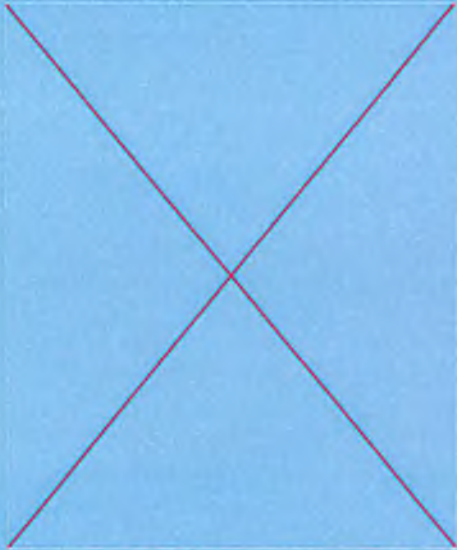

Taylor High School is excited to host **The Plungester** on **March 5, 2026!**

This fun and freezing fundraiser brings our entire school community together while supporting Unified Special Olympics programs.

Why Raise Money for Unified Special Olympics?

Money is raised for Unified Special Olympics Michigan (SOMI) to provide year-round sports, health, and wellness programs to individuals with intellectual disabilities at no cost to them. The funds also support inclusive initiatives like Unified Champion Schools, which promote social inclusion and break down stereotypes.



What's the Polar Plunge?



The water is around 40 degrees and 4 feet deep. There will be people there in and out of the water for extra assistance if needed. For those that cannot use the stairs we will have an ice bucket in a kiddie pool ready for them as well as a confetti cannon for those in wheelchairs!



Our District Wide Goal

We're aiming to raise:

🎯 \$10,000

🎯 100 plungesters

Current progress:

💰 \$4K raised

❄️ 33 registered plungesters

We can easily reach our goal with your help!



Who Can Plunge?



 **High School Students (15+) (must have permission slip signed)**

 **Teachers & Paraprofessionals**

 **Maintenance & Custodial Staff**

 **Bus Drivers**

 **Cafeteria Staff & Cooks**

 **Secretaries, Principals, and Administrators**

✓ **Willing to raise \$50 to become a plungester (and earn some cool swag)**

Our Student Media Team (DECA)

Our amazing DECA students will be on-site to:



Take photos



Record videos

So younger schools can see everything they helped support and feel like they are part of the event!



Important Event Details

 Taylor High School

 March 5, 2026

 Check-in begins at 7:45 AM

 Plunge starts at 8:15 AM

 Any cash collected will be turned in during morning check-in.



Why Your Support Matters



Your participation helps create:

❤️ School unity

🤝 New friendships

😊 Confidence and joy for our special education students

🏠 A stronger, more inclusive school community

Together, we can make a REAL impact!



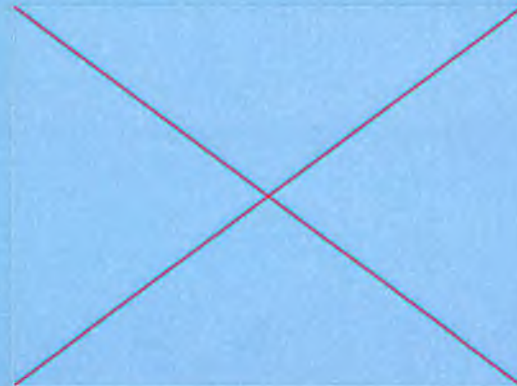
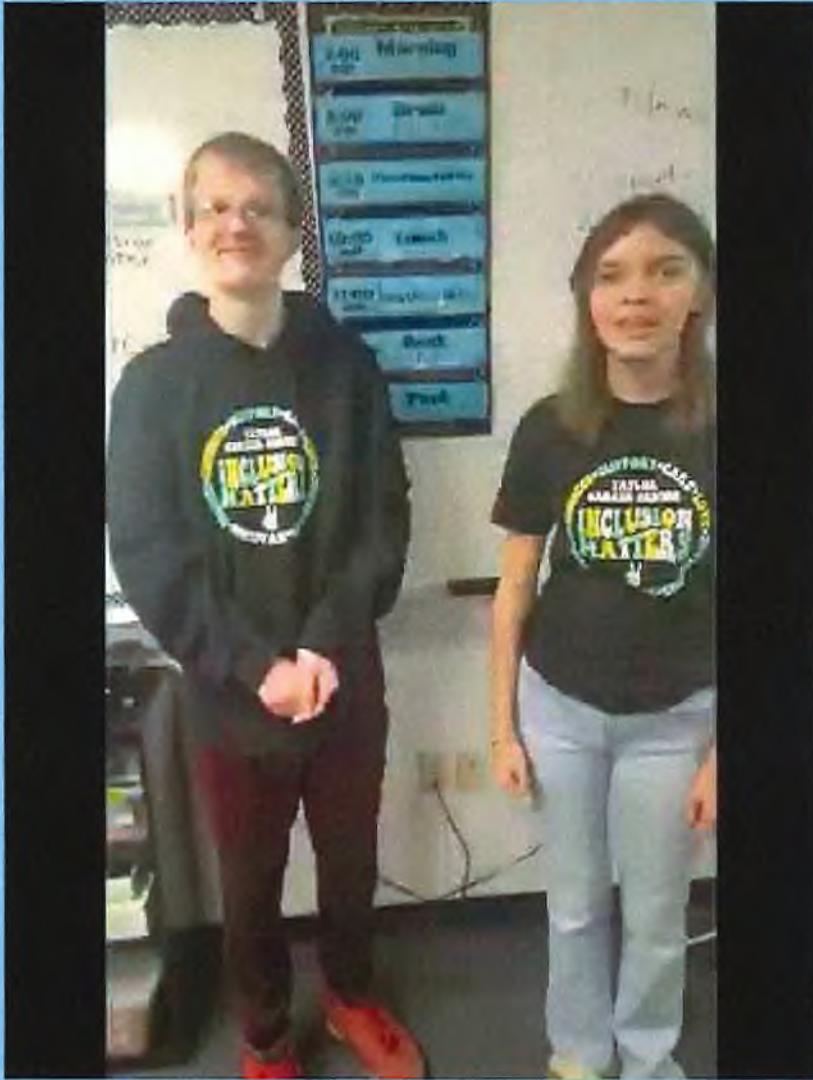

**What Unified
Special
Olympics
means to us!**

Are You Ready?



Scan the QR code to:



Register as a plungester

(only if you are staff of Taylor school district or a high school student)



Donate to support the Taylor School District Plunge

Every contribution directly helps Michigan Unified Special Olympics.



FY26 Budget Amendment 2026-004, dated 2/3/2026

	<u>FROM</u>	<u>TO</u>	<u>INCREASE (DECREASE)</u>	<u>Justification</u>
101 - General Fund				
Revenue Changes:				
			-	
Total Revenue Changes	-	-	-	
Total Fund Revenue	\$ 58,170,341.00	\$ 58,170,341.00	\$ -	
Appropriation Changes:				
101-441-761-160-000-000 DPW - Salt Supply	130,000.00	170,000.00	40,000.00	Increase in salt supply related to increase in use during the year Dump truck cost over originally anticipated
101-441-981-000-000-000 DPW - Vehicles	485,000.00	567,000.00	82,000.00	
Total Appropriation Changes:	615,000.00	737,000.00	122,000.00	
Total Fund Appropriations	\$ 61,207,279.00	\$ 61,329,279.00	\$ 122,000.00	
Net Change in Fund Balance	(3,036,938.00)	(3,158,938.00)	(122,000.00)	
Unrestricted Beginning Fund Balance	24,838,014.00	24,838,014.00	-	
Estimated Ending Fund Balance	21,801,076.00	21,679,076.00	(122,000.00)	
% of Revenue	37.5%	37.3%		



Q-416670 - USD 4,995.00

Quotation

Address:
Magnet Forensics, LLC
931 Monroe Drive NE
Suite A102-340
Atlanta, Georgia 30308
United States

Phone: 519-342-0195

Quote #: Q-416670-1
Issue Date: 20 Jan, 2026
Expires On: 14 Jan, 2026

Bill To

Jordan Chamberlain
Taylor Police Department (MI)
23515 Goddard
Taylor, Michigan 48180
United States
734-287-6611 EXT 2011
jchamberlain@cityoftaylor.mi.gov

Ship To

Jordan Chamberlain
Taylor Police Department (MI)
23515 Goddard
Taylor, Michigan 48180
United States
734-287-6611 EXT 2011
jchamberlain@cityoftaylor.mi.gov

End User

Jordan Chamberlain
Taylor Police Department (MI)
23515 Goddard
Taylor Michigan 48180
United States
734-287-6611 EXT 2011
jchamberlain@cityoftaylor.mi.gov

PREPARED BY	PHONE	EMAIL	PAYMENT TERM
John Bigler	551-574-5607	john.bigler@magnetforensics.com	Net 30

ITEM #	PRODUCT NAME	SMS DATES	UNIT SELLING PRICE	QTY	EXTENDED PRICE
6AXB100	Magnet AXIOM Essentials Bundle		USD 0.00	1	USD 0.00
6AX110	Magnet AXIOM Essentials	12	USD 4,970.00	1	USD 4,970.00
5D000	Shipping - Domestic		USD 25.00	1	USD 25.00

Sub-Total	USD 4,995.00
Taxes	USD 0.00
Grand Total	USD 4,995.00

Prices subject to change upon quote expiry. Accurate sales tax will be calculated at the time of invoicing when applicable. If your company is tax exempt, please provide appropriate support with your signed quote. Hardware may be subject to additional fees related to delivery, import and export.

Terms & Conditions

Unless you have an existing written agreement with Magnet Forensics for the products and/or services listed in this quotation, by: (a) signing below, (b) submitting an Order to Magnet Forensics referencing this quotation, or (c) making payment for the products and/or related services listed in this quotation, you agree to the terms and conditions at <http://magnetforensics.com/legal/> applicable to such products and/or services listed in this quotation to the exclusion of any differing or additional terms which may be found on your purchase order or similar document. By signing, you certify that you have the authority to bind your organization.

101-301-818-258-000-000

Q-416670 - USD 4,995.00

Magnet Forensics may adjust the software term start and/or end date, without increasing the total software license price, based on the date Magnet Forensics activates the software and provided that the total software license term length does not change.

Signature: _____

Date: ____/____/____

Name (Print): _____

Title: _____

Please sign and email to John Bigler at john.bigler@magnetforensics.com



Q-416670 - USD 7,999.00

Quotation

Address:
Magnet Forensics, LLC
931 Monroe Drive NE
Suite A102-340
Atlanta, Georgia 30308
United States

Phone: 519-342-0195

Quote #: Q-416670-1
Issue Date: 20 Jan, 2026
Expires On: 14 Jan, 2026

Bill To
Jordan Chamberlain
Taylor Police Department (MI)
23515 Goddard
Taylor, Michigan 48180
United States
734-287-6611 EXT 2011
jchamberlain@cityoftaylor.mi.gov

Ship To
Jordan Chamberlain
Taylor Police Department (MI)
23515 Goddard
Taylor, Michigan 48180
United States
734-287-6611 EXT 2011
jchamberlain@cityoftaylor.mi.gov

End User
Jordan Chamberlain
Taylor Police Department (MI)
23515 Goddard
Taylor Michigan 48180
United States
734-287-6611 EXT 2011
jchamberlain@cityoftaylor.mi.gov

PREPARED BY	PHONE	EMAIL	PAYMENT TERM
John Bigler	551-574-5607	john.bigler@magnetforensics.com	Net 30

ITEM #	PRODUCT NAME	SMS DATES	UNIT SELLING PRICE	QTY	EXTENDED PRICE
3AT02	Magnet Forensics Training Annual Pass	12	USD 7,999.00	1	USD 7,999.00

Sub-Total	USD 7,999.00
Taxes	USD 0.00
Grand Total	USD 7,999.00

Prices subject to change upon quote expiry. Accurate sales tax will be calculated at the time of invoicing when applicable. If your company is tax exempt, please provide appropriate support with your signed quote. Hardware may be subject to additional fees related to delivery, import and export.

Terms & Conditions

Unless you have an existing written agreement with Magnet Forensics for the products and/or services listed in this quotation, by: (a) signing below, (b) submitting an Order to Magnet Forensics referencing this quotation, or (c) making payment for the products and/or related services listed in this quotation, you agree to the terms and conditions at <http://magnetforensics.com/legal/> applicable to such products and/or services listed in this quotation to the exclusion of any differing or additional terms which may be found on your purchase order or similar document. By signing, you certify that you have the authority to bind your organization.

101-301-955-204-000-000

Q-416670 - USD 7,999.00

Magnet Forensics may adjust the software term start and/or end date, without increasing the total software license price, based on the date Magnet Forensics activates the software and provided that the total software license term length does not change.

Signature: _____

Date: ____/____/____

Name (Print): _____

Title: _____

Please sign and email to John Bigler at john.bigler@magnetforensics.com

Cellebrite Inc.
 8065 Leesburg Pike,
 Suite T3-302
 Vienna, VA 22182
 USA

Tel. +1 800 942 3415
 Fax. +1 201 848 9982
 Tax ID#: 22-3770059
 DUNS: 033095568
 CAGE: 4C9Q7
 Company Website:
<http://www.cellebrite.com>

Quote

Quote#: Q-491039-1
Date: Dec 29, 2025

Billing Information
 Taylor Police Department
 23515 Goddard Taylor
 Goddard Taylor, Michigan 48180
 United States

Delivery Information

Contact:
Phone:

Wire To:
 Bank Routing Number: 021000021
 Account Number: 761020590
 Account Name: Cellebrite Inc.

Check Remittance (Only for NA):
 Cellebrite Inc. ,
 PO BOX 23551
 New York, NY, 10087-3551

Contact:
Phone:

End Customer: Taylor Police Department

Customer ID	Good Through	Payment Terms	Currency	Sales Rep
SF-00197008	Jan 28, 2026	Net 30	USD	Gabriel McAndrew

#	Product Code	Product Name	Qty	Start Date	End Date	Net Price\Unit	Net Price
1	B-CNR-08-001	Inseyets Pro PA Stand Alone	1	Dec 29, 2025	Dec 28, 2026	4,430.00	4,430.00
2	S-UFD-20-007	Inseyets Pro PA Standalone Subscription	1	Dec 29, 2025	Dec 28, 2026		
3	F-KAS-00-001	UFED Dongle Kit	1				
4	S-UFD-04-059	Smart Translator (3 languages translation Promotion)	1	Dec 29, 2025	Dec 28, 2026		
Number of Languages: 3							
5	U-TRN-02-119	In-Person/Virtual (CCPA) - Certified Physical Analyst Inseyets (3 days)	1	Dec 29, 2025	Dec 28, 2026	2,990.00	2,990.00

SubTotal	USD 7,420.00
Shipping & Handling	USD 0.00
Sales Tax	USD 0.00
Total	USD 7,420.00

Cellebrite
[C2C]
 USER SUMMIT

Your Next Career Step
 Ask your Account Manager about special ticket offers.

JOIN US

Comments:

Terms and Conditions:

- This Quote/Proforma Invoice/Tax Invoice, together with the terms and conditions and license agreement listed below that are incorporated by reference to this Quote/Proforma Invoice (together, the "Agreement"), constitute an offer by Cellebrite. By signing this the Quote/Proforma Invoice, issuing a purchase order (or other ordering document) in connection with this the Quote/Proforma Invoice, or downloading and/or using the products identified in this the Quote/Proforma Invoice/Tax Invoice, the customer agrees to be bound by the terms of this Agreement. Any additional or different terms or conditions contained in any customer document, purchase order or other ordering document will not be binding upon Cellebrite unless expressly accepted in a document signed by a Cellebrite authorized signatory.

- Freight Terms: FCA (NJ)

- General: The following terms shall apply to any product at <http://legal.cellebrite.com/us/index.html>

- EULA: All Cellebrite Software is licensed subject to the end user license agreement available at <https://legal.cellebrite.com/End-User-License-Agreement.html>

- Advanced Services (CAS): The following terms apply to Cellebrite Advanced Services at <https://legal.cellebrite.com/CB-us-us/index.html>

- Premium and Inseyets Unlocks: The following terms shall apply only to Cellebrite Premium and Inseyets Unlocks at <http://legal.cellebrite.com/intl/PremiumUS.htm>

- Pathfinder: The following terms apply to Cellebrite Pathfinder at <https://legal.cellebrite.com/PF-Addendum.htm>

- Training Services: The following terms apply to Cellebrite Training Services at <http://legal.cellebrite.com/intl/Training.htm>

- SaaS: The following terms apply to Cellebrite SaaS Services at <https://legal.cellebrite.com/SaaS.htm>

- Endpoint SaaS: The following terms apply to Cellebrite Cellebrite Endpoint SaaS at <https://legal.cellebrite.com/Endpoint-SAAS.html>

In the event of any dispute as to which terms apply, Cellebrite shall have the right to reasonably determine which terms apply to a given purchase order.

Please indicate the invoice number when remitting payment

*SALES TAX DISCLAIMER: Cellebrite Inc. is required to collect Sales and Use Tax for purchases made from the following certain U.S. States. Orders are accepted with the understanding that such taxes and charges shall be added, as required by law. Where applicable, Cellebrite Inc. will charge sales tax unless you have a valid sales tax exemption certificate on file with Cellebrite Inc. Cellebrite Inc. will not refund tax amounts collected in the event a valid sales tax certificate is not provided. If you are exempt from sales tax, you must provide us with your sales tax exempt number and fax a copy of your sales tax exempt certificate to Cellebrite Inc.

Please include the following information on your PO for Cellebrite UFED purchase:

- Please include the ORIGINAL QUOTE NUMBER (For example - Q-XXXXX) on your PO

- CONTACT NAME & NUMBER of individual purchasing and bill to address

- E-MAIL ADDRESS of END USER for monthly software update as this is critical for future functionality

I, the undersigned, hereby confirm that I am authorized to sign this Quote/Proforma Invoice on behalf the customer identified above, and I hereby approve that my signature is legally binding upon the customer identified above.

Customer Name: Taylor Police Department

Signature: _____

Effective Date: _____/_____/_____

Name (Print): _____

Title: _____

Please sign and email to Gabriel McAndrew at gabriel.mcandrew@cellebrite.com

Passware Kit Mobile

Forensic tool that extracts and decrypts user data from mobile devices.

Buy Now \$2,490 →

Trial \$295 →

Download Product Sheet

NEW

View 2026.1 Features

Overview & Licensing Options

What's New

Supported Devices



Decrypt an Apple Device

Connect Device | Set Up | Recovery | Attack Scenarios | Recovery

PUT THE DEVICE IN DFU MODE FROM RECOVERY MODE

How to put an Apple Device in DFU Mode

Waiting for the device in Recovery Mode...

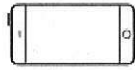

1. Connect the device to this computer with a USB cable.

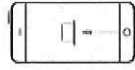

2. Enter the Recovery Mode: press and hold the Lock and Home buttons until you see iTunes or Macbook logo on the device screen.



3. Release the buttons, then press again and hold the Lock and Home buttons until you see iTunes or Macbook logo on the device screen.



4. Release the Lock button but keep pressing the Home button.

Waiting for the device...

Optimum Contracting Solutions LLC

"We are the Solution"

INVOICE

DATE: January 15, 2026

Invoice# 16046-001

FOR:

Bill To:

City of Taylor
23555 Goddard Rd.
Taylor, MI 48180

Address:

Taylor, MI 48180

DESCRIPTION	AMOUNT
Furnace	\$ 4,850.00
AC	\$ 4,775.00
Humidifier	\$ 725.00
TOTAL	\$10,350.00

Homeowner Signature: _____ **Date:** Jan 15, 2026

Contractor Signature: _____ **Date:** 1/15/2026

Thank You For Your Business!

Bid Tabulation

16046 Allen ~~PAK~~ Emergency Rehab *Ref*

Name of Vendor	Address	Telephone	Price	Comments & Recommendations
A to Z Total Heating and cooling	24614 Van Born Rd Dearborn Heights, Michigan, 48125 United States	313-291-8200	\$9105.00	DISQUALIFIED No active SAM.GOV/UIE #
Optimum Contracting Solutions	2211 Devonshire Rd. Bloomfield Hills, Michigan, 48302 United States	248-346-3069	\$11,125.00	RECOMMEND
J.E. Johnson	P.O.Box 1863 Midland, Michigan, 48641 United States	989-835-6671 ext 1245	\$15,770.98	

Bid Tabulation

Purchasing Agent Signature: Signed Date: 12/21/2025Time: 10:30

Vendor	Amount	Released	Balance	Moves	Date	Amount Approved By Council	INCREASES
Gas and Oil 226-528-751-000-000-000							
Eastern Oil Company	\$ 10,000.00	\$ -	\$ 10,000.00			\$10,000	
RKA Petroleum	\$ 60,000.00	\$ 52,101.88	\$ 7,898.12			\$60,000	\$100,000
	\$ 70,000.00	\$ 52,101.88	\$ 17,898.12				
Uniforms 226-528-767-000-000-000							
DO Apparel	\$ 2,000.00	\$ 930.00	\$ 1,070.00			\$2,500	
Unifirst Corp	\$ 1,500.00	\$ 326.47	\$ 1,173.53			\$4,000	
	\$ 3,500.00	\$ 1,256.47	\$ 2,243.53				
Contractual Services 226-528-818-628-000-000							
Buck's Oil Co. Inc	\$ 2,500.00	\$ -	\$ 2,500.00			\$2,500	
	\$ 2,500.00	\$ -	\$ 2,500.00				
Building/ Site Repair & Maintenance 226-528-930-000-000-000							
AIS Construction Equipment	\$ 2,000.00	\$ -	\$ 2,000.00			\$2,500	
Stoneco of Michigan	\$ 10,000.00	\$ 6,731.74	\$ 3,268.26			\$10,000	
	\$ 12,000.00	\$ 6,731.74	\$ 5,268.26				
Operating Supplies 226-528-761-000-000-000							
A&L Great Lakes Laboratories Inc	\$ 2,000.00	\$ -	\$ 2,000.00			\$2,500	
American Hydraulics	\$ 2,000.00	\$ 450.00	\$ 1,550.00			\$2,500	\$10,000
Exotic Automation	\$ 2,000.00	\$ 1,757.49	\$ 242.51			\$2,500	\$10,000
Fastenal Company	\$ 2,000.00	\$ 804.10	\$ 1,195.90			\$2,500	\$5,000
Grainger	\$ 2,000.00	\$ -	\$ 2,000.00			\$2,500	
Grand Rapid Metrology	\$ 4,000.00	\$ 652.88	\$ 3,347.12			\$5,000	
Herkimer Radio Service	\$ 2,000.00	\$ -	\$ 2,000.00			\$2,500	
Home Depot Credit Services	\$ 2,500.00	\$ 1,383.63	\$ 1,116.37			\$2,500	
Hutson Inc of Michigan	\$ 2,500.00	\$ 550.18	\$ 1,949.82			\$2,500	
Maverick	\$ 7,500.00	\$ 2,131.86	\$ 5,368.14			\$10,000	\$15,000
Quench	\$ 2,000.00	\$ 306.15	\$ 1,693.85			\$2,500	
S&S Parts LLC	\$ -	\$ -	\$ -	\$2,500		\$2,500	\$5,000
Security ACE Hardware	\$ 2,000.00	\$ 264.25	\$ 1,735.75			\$2,500	
Versalift Midwest LLC	\$ 2,000.00	\$ -	\$ 2,000.00			\$2,500	\$5,000
Wolverine Truck	\$ 2,500.00	\$ -	\$ 2,500.00			\$2,500	\$5,000
	\$ 37,000.00	\$ 8,300.54	\$ 28,699.46				
Equipment Repair & Maintenance 226-528-931-000-000-000							
ALTA Construction Equipment	\$ 20,000.00	\$ 19,913.03	\$ 86.97			\$20,000	\$30,000
Auto Value	\$ -	\$ -	\$ -			\$20,000	
Belle Tire	\$ -	\$ -	\$ -			\$2,500	
Ecoverse	\$ -	\$ -	\$ -			\$2,500	
Metro Truck	\$ 2,000.00	\$ 1,449.60	\$ 550.40			\$2,500	
Michigan CAT	\$ 7,500.00	\$ 6,158.80	\$ 1,341.20			\$20,000	
NAPA Genuine Auto Parts	\$ 1,000.00	\$ 906.24	\$ 93.76			\$2,500	
Pomp's Tire	\$ 2,000.00	\$ 1,196.58	\$ 803.42			\$6,000	\$10,000
Smiley Tire	\$ -	\$ -	\$ -			\$2,500	
Southpointe Radiator	\$ 1,500.00	\$ 1,185.37	\$ 314.63			\$2,500	\$5,000
Sparks Tire	\$ 1,000.00	\$ 998.34	\$ 1.66			\$2,500	\$5,000
Vermeer	\$ 5,000.00	\$ 1,430.88	\$ 3,569.12			\$38,500	
	\$ 40,000.00	\$ 33,238.84	\$ 6,761.16				

TRUCK & TRAILER *Specialties, Inc.*

900 Grand Oaks Drive | Howell, MI 48843 | www.ttspec.com | ph: (517) 552-3855 | fx: (517) 552-3666

January 13, 2026

City of Taylor
23555 Goddard Road, Taylor, MI 48180
Attn: Ralph Richard, ph: (734) 374-1427, Jason Mach, ph: (734) 231-7550 & Brad Snider, ph: (313) 670-7052
HQ0005740

Equipment Quotation

The following pricing will be based on City of Rochester Hills RFP-RH-20-023 contract awarded September 2020

- Install Crysteel 11' Select Dump Body including the following:**
132" length, 50" front height, 30" side height and 38" rear height (6-8 cubic yard capacity water level)
84" interior width and 96" exterior width
Single panel pressed-in horizontal side braces
7-gauge 201 stainless steel front, sides and rear pillars
¼" AR450 floor with 8" floor-to-side radius
8" I-beam type understructure
14" wide rear pillar
Air-operated tailgate release
6-panel tailgate design constructed of 7-gauge 201 stainless steel
Tailgate finger latches and pivot plate are stainless steel construction
Body prop kit on each side of the frame
Install 10" hardwood sideboards (8 yd capacity with sideboards)
Install stainless steel fold-down ladder, driverside front of dump
Install two (2) shovel holders cabshield mounts, both on curbside
Install two (2) weld-on grab handles at base of tailgate (10" wide, 2-3" standoff)
Install branch deflector on cabshield, passenger-side, constructed of stainless steel
Install license plate brackets in upper-left corner of tailgate
Install mudflaps fore and aft of rear tires
- Install ½ cabshield constructed of 10-gauge 201 stainless steel, free-standing mounted to truck frame**
- Install Mailhot model G4100-4.25-3 DA Telescopic Hoist including the following:**
Greaseable rear hinge and replaceable rear stainless steel pin
Hoist is double-acting and trunnion-mounted
Install remote grease extension kit for Mailhot hoists
- Install Roll-Rite Electric Tarp System including the following:**
Aluminum tarp housing model 63000
Direct-drive motor
Mesh-type tarp cover
- Install Central Hydraulic System including the following:**
Rexroth A10VO85 front-mounted load-sense piston pump
Pump is 85CC displacement
Low-oil shutdown valve and override circuit
Spicer drive line with companion flange for easy removal
- Install Monroe Combination Hydraulic Oil Reservoir/Valve Enclosure including the following:**
7-gauge type 201 stainless steel construction (mos. 00141843 & 15570)
40-gallon oil capacity filled with 35-gallon AW32 hydraulic oil
Valve enclosure will be installed on the streetside of the combo tank with a lockable "T" handle latch

TRUCK & TRAILER *Specialties, Inc.*

900 Grand Oaks Drive | Howell, MI 48843 | www.ttspec.com | ph: (517) 552-3855 | fx: (517) 552-3666

5 PSI pressurized tank cap on hydraulic tank
3" supply port on hydraulic tank with 3" x 2" suction strainer
2" ball valve shut-off for supply line to the hydraulic pump
¾" case drain shut-off
Tank-mounted return line oil filter
Ball valve shut-offs on both fuel supply and return lines
Low-oil sensor mounted in the top of the tank
Sight gauge/Temperature gauge
Tank labels
All necessary hoses and fittings

Install Stainless steel step mounted on the end of the tank mounting bracket assembly

Install Rexroth 7m4-12 load-sense hydraulic valve mounted inside the oil/valve enclosure with pressure-compensated flow controls for the following functions:

Hoist w/ 500 PSI A-port load-sense relief
Scraper up/down w/ 500 PSI A-port load-sense relief
Scraper angle
Front Plow up/down
Front Plow angle
EPC section for auger
EPC section for spinner

Install stainless steel pipe to the rear for spreader circuits & all necessary hoses and fittings
Install stainless steel quick couplers for spreader & front plow circuits with dust caps & plugs
All necessary hoses and fittings

Install Rexroth CS620 Electric Spreader Controller including the following:

Designed to operate in manual mode, including pause & blast features
Controller mounted between the seats on a console

Install Apsco Air-type Levers for Scraper, Dump Hoist & Front Plow including the following:

Order of single-axis levers (L-R):
#1 Scraper up/down
#2 Scraper angle
#3 Dump Hoist w/safety detent
#4 Front Plow up/down
#5 Front Plow angle

Install Monroe 29" Hustling-type Front Hitch (centerpin at 37") including the following:

12" structural C-channel front bumper with tapered back ends
Double-acting 3" x 10" lift cylinder on hitch with Socatri rod
Front tow hooks installed on kicker legs
Install Roller Assembly Kit plate, hitch-portion (plow required at time of build to mount plate height)
All necessary supports and braces

Install Monroe 10' model MS4510 Underbody Scraper including the following:

1" thick x 20" high moldboard
½" thick hanger board with grease manifold brackets installed
2-1/2" O.D. hinge shaft
Two heavy-duty shock absorbers
Bolt-in trunnion caps for canisters; outer arm remains bolt-on style
Two 3-1/2" x 10" actuating cylinders; Socatri rods
Cushion valve & hydraulic pipes
1" solid circle with 5" center pin that is piloted into hanger board
Two 4" x 12" reversing cylinders; Socatri rods

TRUCK & TRAILER *Specialties, Inc.*

900 Grand Oaks Drive | Howell, MI 48843 | www.ttspec.com | ph: (517) 552-3855 | fx: (517) 552-3666

Three hinge anchor points
20.5" x 7" poly hold-down blocks
Hose kit and j-50 type relief valve
¾" solid hanger plates & mounting hardware
Grease line kit with manifolds
Parts-installation manual
Install one (1) Kennametal carbide curbguard on curbside end of moldboard
Install serrated safety step on driverside end of moldboard
Paint ends of moldboard Yellow to match cab

Install Monroe model MS966-RF-GB Undertailgate Spreader including the following:

Type 201 stainless steel construction, unpainted
7-gauge trough and ¾" endplates, stainless steel inner tailgate shields
6" auger with reverse-flighting and 4" flight spacing for center-left discharge
5:1 gear box with direct-mounted motor
Extended integral side plates on spreader
Spinner motor includes a seal-saver kit with grease zerk
Trough-hung self-leveling spinner with 18" poly spinner disc
Full top and bottom opening
Stainless steel hydraulic quick couplers for auger and spinner circuits

Install Custom Lighting & Electrical including the following:

Chassis OEM switches for: front flashers, all flashers, rear green flashers, scraper light, spreader light & tarp open/close
Chassis switch indicators for: pump shutdown, low-oil & body-up
Console switches for: pump shutdown/override, large toggle pause/blast & air-tailgate w/ safety cap
LED Heated Plow Lights with aluminum mounting brackets on the hood, mounted 67" up from ground
Install Maxxima LED Heated Truck Headlights (mo. MHLE-07HILO-MH), return OEM halogens to City
Six (6) SoundOff mPower (mo. EMPS20V38-P) amber/green LED flashers flush-mounted:
 Two (2) mounted in chassis grille (on separate switch)
 Two (2) cabshield-mounted front-facing under cabshield
 Two (2) cabshield-mounted side-facing at bottom of cabshield
Stainless steel 4-hole 6" light boxes at rear of body with the following:
 Two (2) SoundOff oval LED solid amber flashers in top holes
 Two (2) SoundOff oval LED STT lights, 2nd from top
 Two (2) SoundOff oval LED backup lights, 3rd from top
 Two (2) SoundOff oval LED solid green flashers in bottom holes (separate switch)
One (1) Maxxima LED 4" work light on curbside for Scraper
One (1) Maxxima LED 4" work light at rear streetside for Spreader
3-light cluster at hinge, above hitch plate
Battery "off" indicator LED button-light tied into battery disconnect, mounted in cab skirt
SoundOff LED markers on rear corners of body
Proximity switch for dump body-up light
Backup alarm
Betts junction box at the rear for chassis lighting circuits and trailer wiring circuits

Install ¾" Steel Rear Hitch Plate including the following:

PH20 Pintle hook; multi-drill hitch plate for adjustable mounting, mounted 22" from ground to cradle
Two (2) heavy-duty D-rings for safety chains
Tow hooks on sides of frame
7-way round-pin plug for ABS trailer (wiring schematic needed)
7-way round-pin plug for non-ABS trailer (wiring schematic needed)

TRUCK & TRAILER *Specialties, Inc.*

900 Grand Oaks Drive | Howell, MI 48843 | www.ttspec.com | ph: (517) 552-3855 | fx: (517) 552-3666

Remount OEM glad hands

Install Electric Brake Controller

Install 3-step egress under driver door, top step allowing fuel tank access, painted Yellow to match cab

Install Minimizer Floor Mats for Freightliner 108 SD (mo. FKFRTL2B-MIN / 10002265)

Paint Front hitch, under dump body and rear hitch area painted Black

Above equipment installed & painted pricing: \$120,872.00 ea.

Chassis requirements to be confirmed prior to order entry:

CA: 118"

Highest ground clearance package

Battery disconnect switch in floor, outboard of driver seat

DPF mounted behind cab, right side with a vertical tailpipe

Front PTO provision

Trailer wiring to rear & air to the rear with OEM glad hands

Additional 7-way round pin plug wiring to rear

Front frame extension

Delete OEM front bumper

Low-profile 50-gallon fuel tank mounted under driver's door, raised mounting

Stationary grille

Programmable six (6) chassis switches

Plow light/Headlight switch and related OEM wiring

Minimum full 1-year warranty on parts and labor on all equipment.

Payment Terms: Net 30. Pricing effective for 30 days.

Pricing does not include any of the Rochester Hills RFQ discounts that may be applicable.

2% discount off total taken at invoice if payment is received within 30 days.

FOB: City of Taylor

Delivery: 16-18 months ARO

Thank you for the opportunity to quote.

Respectfully submitted by,

Jon Luea/Brian Bouwman



107 S. Groesbeck • Mt. Clemens, MI 48043 • (586) 783-2444 FAX (586) 469-8054

12/12/2025

City of Taylor
RE: RH Co-Op Chassis Pricing

Attn: Mr. Jason Mach

The following is Freightliner chassis pricing information per your request. Pricing and conditions are per the Rochester Hills Co-op RFP-RH-20-023 agreement.

Single Axle 39,000 GVW Single Axle, 2026 Model

Chassis Model: 108SD PLUS

Base Chassis Price 2021 MY:	\$84,993
2022 Model Year escalator.....	\$ 900 add
2023 Model Year Increase	\$ 1,000 Add
2023 Surcharges	\$ 6,700 Add
2024 Pricing & Surcharges	\$ 5,925 Add
2025 Model & Surcharge	\$ 5,500 Add
Freightliner 108SD Plus upgrade	\$ 2,000 Add
2026 Model Increase & surcharge.....	\$ 4,305 Add
2027 Model Increase	\$ 3,750 Add
2027 Tariff Fee	\$ 1,500 Add
Block Heater.....	\$ 45 Add
Locking Differential.....	\$ 530 Add
Hendrickson Primaax 26K suspension upgrade	\$ 1,450 Add
Fender Extenders	\$ 50 Add
Safety Pkg	\$ 187 Add
Driver's seat 3 chamber upgrade	\$ 134 add
Power Windows/doors	\$ 219 add
6 Programable switches	\$ 208 Add
Cooling System- Ext Warranty 5/100	\$ 305 Add
No front engine PTO	\$ 275 Deduct

TOTAL: (Not to Exceed) \$ 117,621 each

*In accordance with the Rochester Hills Co-op contract, the chassis will be invoices Once the chassis is inspected and/or approved to go to the body company. 30-60 terms.

Steven Sexton
Municipal Sales Manager
Wolverine Truck Group

**CITY OF ROCHESTER HILLS ACTING AS LEAD AGENCY
AWARD OF PROPOSAL RFP-RH-20-023
SINGLE/TANDEM AXLE DUMP TRUCK CHASSIS' RELATED PARTS, EQUIPMENT
AND SERVICES
MASTER AGREEMENT
CITY OF ROCHESTER HILLS**

This agreement made this 25th day of September 2020, by and between the **City of Rochester Hills, 1000 Rochester Hills Drive, Rochester Hills, Michigan 48309**, hereinafter called the CITY and **Wolverine Freightliner, 107 S. Groesbeck, Mt. Clemens, MI 48043** hereinafter called the CONTRACTOR. NOW THEREFORE, the CONTRACTOR and the CITY, for the consideration hereinafter named, agree as follows:

ADMINISTRATIVE SUMMARY

- Request for Proposals were posted on February 10, 2020 on the MITN e-procurement system and opened on April 8, 2020. The City, acting as Lead Agency on behalf of themselves, City of Auburn Hills, City of Farmington Hills, City of Livonia, City of Madison Heights and Charter Township of Bloomfield issued a Request for Proposal for the purchase of Single/Tandem Axle Dump Trucks, Parts, and Related Equipment/Services. The proposal was developed with the intent of procuring single and tandem axle dump trucks meeting the City's and participating agencies specifications, and obtaining pricing that would offer a comprehensive list of options, equipment, parts and related services for dump trucks, creating an extendable agreement for use by entities in the MITN Purchasing Cooperative to purchase from, and aggregate volume to generate best value offers from vendors.
- Notification was sent to over 100 vendors with five (5) proposal responses received.
- The proposals were evaluated by the City of Rochester Hills Fleet Personnel, as well as representatives from the City of Farmington Hills, City of Livonia, and the City of Madison Heights.
- Scoring for the proposal process were conducted and Wolverine Truck Group was selected and unanimously selected by the entities as providing the best value and services for the truck chassis' portion of the contract.
- Wolverine Truck Group represents the Freightliner line of chassis'.
- At their, September 21, 2020 meeting, the City of Rochester Hills authorized award of the agreement to Wolverine Truck Group. With execution of this agreement, the City of Rochester Hills hereby awards the contract for Single/Tandem Axle Dump Truck Chassis' Related Parts, Equipment, and Services to Wolverine Truck Group for a period of three years, commencing October 1, 2020 with an option to renew for an additional two (2) year term under the same terms and conditions upon mutual consent by the City and Contractor.

NOW THEREFORE, the CONTRACTOR and the CITY, for consideration hereinafter named, agree as follows:

**CITY OF ROCHESTER HILLS ACTING AS LEAD AGENCY
AWARD OF PROPOSAL RFP-RH-20-023
SINGLE/TANDEM AXLE DUMP TRUCK CHASSIS' RELATED PARTS, EQUIPMENT
AND SERVICES
MASTER AGREEMENT
CITY OF ROCHESTER HILLS**

WHEREAS, The City of Rochester Hills has entered into a Master Agreement by and between the CITY and CONTRACTOR, (as may be amended from time to time in accordance with the terms thereof, the "Master Agreement"), for the purchase of Single/Tandem Axle Dump Truck Chassis', Related Parts and Services.

WHEREAS, said Master Agreement provides that any MITN Purchasing Cooperative Member may purchase Product at prices and pricing structure stated in the Master Agreement. Each entity is responsible for its own payments and is to be considered individually for billing and collection purposes. Each entity will provide its own purchase order and delivery location(s) and must be invoiced separately to the address indicated on their purchase order.

WHEREAS, City of Rochester Hills serves as the Contract Administrator with regards to the Master Agreement.

WHEREAS, The CONTRACTOR agrees to provide all labor, materials, equipment and the means of work to perform **Single/Tandem Axle Dump Truck Chassis', Related Parts and Services**, as indicated in Request for Proposal (RFP-RH-20-023 for Single/Tandem Axle Dump Trucks, Related Parts and Services) dated February 10, 2020. Work and compensation shall be based on the Contractor's proposal dated March 16, 2020, subsequent email communication regarding pricing dated July 21, 2020 and the RFP Documents (RFP-RH-20-023 for Single/Tandem Axle Dump Trucks, Related Parts, and Services) and Addendums and attachments included as part of this Agreement.

CONTRACT GENERAL CONDITIONS

With respect to any purchases by any Participating Public Agency pursuant to the Master Agreement, the City of Rochester Hills (i) shall not be construed as a dealer, re-marketer, representative, partner or agent of any type of the Supplier, or such Participating Public Agency; (ii) shall not be obligated, liable or responsible for any order made by any Participating Public Agency or any employee thereof under the Master Agreement or for any payment required to be made with respect to such order; and (iii) shall not be obligated, liable or responsible for any failure by any Participating Public Agency to comply with procedures or requirements of applicable law or the Master Agreement or to obtain the due authorization and approval necessary to purchase under the Master Agreement. The City of Rochester Hills makes no representation or guaranty with respect to any minimum purchases by the City or any Participating Public Agency or any employee thereof under this Agreement or the Master Agreement.

INSURANCE

The Contractor shall continuously maintain, during the life of the Contract, insurance coverage of the type specified below. The amount of insurance shall be not less than specified in the contract documents.

- (1) Workman's Compensation Insurance as required by the State of Michigan.
- (2) General Liability with the following coverage inclusions:
 - a. Broad Form General Liability endorsement or equivalent.

**CITY OF ROCHESTER HILLS ACTING AS LEAD AGENCY
 AWARD OF PROPOSAL RFP-RH-20-023
 SINGLE/TANDEM AXLE DUMP TRUCK CHASSIS' RELATED PARTS, EQUIPMENT
 AND SERVICES
 MASTER AGREEMENT
 CITY OF ROCHESTER HILLS**

b. General Liability, Independent Contractor coverage, Products and Completed Operations, Contractual Liability.

(3) Vehicle Liability Coverage and Michigan No-Fault Coverage including all owned, non-owned and hired vehicles.

B. All insurance shall be carried with Insurance Companies authorized to do business in the State of Michigan.

In witness whereof, the Parties hereto have executed this Agreement the day and year written above.

CITY OF ROCHESTER HILLS

Signature

Bryan K. Barnett

Name

Mayor

Title

9/25/2020

Date

WOLVERINE FREIGHTLINER

Steven A. Sexton
Signature

Steven A. Sexton

Name

Municipal Sales Manager

Title

9/25/20

Date

AGENCY CUSTOMER ID: WOLVTRU-01

LOC #: _____



ADDITIONAL REMARKS SCHEDULE

Page 1 of 1

AGENCY The Campbell Group		NAMED INSURED Wolverine Freightliner Eastside, Inc. 107 S Groesbeck Hwy Mount Clemens MI 48043-	
POLICY NUMBER			
CARRIER	NAIC CODE	EFFECTIVE DATE:	

ADDITIONAL REMARKS

THIS ADDITIONAL REMARKS FORM IS A SCHEDULE TO ACORD FORM,
 FORM NUMBER: 30 FORM TITLE: CERTIFICATE OF GARAGE INSURANCE

Garage and Garage Keepers Liability: Any person or organization is additional insured on a primary/non-contributory basis and a waiver of subrogation shall apply in their favor.
 The above conditions apply to the City of Rochester Hills (the City of Auburn Hills, The City of Farmington Hills, City of Madison Heights, City of Livonia, and Bloomfield Township), all elected and appointed officials, all employees and volunteers, all boards, commissions and/or authorities and board members, including employees and volunteers thereof.
 A 30 day notice of cancellation applies.

Request for Taxpayer Identification Number and Certification

Give Form to the requester. Do not send to the IRS.

▶ Go to www.irs.gov/FormW9 for instructions and the latest information.

1 Name (as shown on your income tax return). Name is required on this line; do not leave this line blank.

WOLVERINE FREIGHTLINER EASTSIDE INC

2 Business name/disregarded entity name, if different from above

3 Check appropriate box for federal tax classification of the person whose name is entered on line 1. Check only one of the following seven boxes.

Individual/sole proprietor or single-member LLC C Corporation S Corporation Partnership Trust/estate

Limited liability company. Enter the tax classification (C=C corporation, S=S corporation, P=Partnership) ▶ _____
Note: Check the appropriate box in the line above for the tax classification of the single-member owner. Do not check LLC if the LLC is classified as a single-member LLC that is disregarded from the owner unless the owner of the LLC is another LLC that is not disregarded from the owner for U.S. federal tax purposes. Otherwise, a single-member LLC that is disregarded from the owner should check the appropriate box for the tax classification of its owner.

Other (see instructions) ▶

4 Exemptions (codes apply only to certain entities, not individuals; see instructions on page 3):

Exempt payee code (if any) _____

Exemption from FATCA reporting code (if any) _____

(Applies to accounts maintained outside the U.S.)

5 Address (number, street, and apt. or suite no.) See instructions.

107 SOUTH GROESBECK HIGHWAY

6 City, state, and ZIP code

MOUNT CLEMENS, MI 48043

Requester's name and address (optional)

CITY OF ROCHESTER HILLS

7 List account number(s) here (optional)

Print or type. See Specific Instructions on page 3.

Part I Taxpayer Identification Number (TIN)

Enter your TIN in the appropriate box. The TIN provided must match the name given on line 1 to avoid backup withholding. For individuals, this is generally your social security number (SSN). However, for a resident alien, sole proprietor, or disregarded entity, see the instructions for Part I, later. For other entities, it is your employer identification number (EIN). If you do not have a number, see *How to get a TIN*, later.

Note: If the account is in more than one name, see the instructions for line 1. Also see *What Name and Number To Give the Requester* for guidelines on whose number to enter.

Social security number									

or

Employer identification number									
3	8	-	3	4	3	1	0	8	6

Part II Certification

Under penalties of perjury, I certify that:

- The number shown on this form is my correct taxpayer identification number (or I am waiting for a number to be issued to me); and
- I am not subject to backup withholding because: (a) I am exempt from backup withholding, or (b) I have not been notified by the Internal Revenue Service (IRS) that I am subject to backup withholding as a result of a failure to report all interest or dividends, or (c) the IRS has notified me that I am no longer subject to backup withholding; and
- I am a U.S. citizen or other U.S. person (defined below); and
- The FATCA code(s) entered on this form (if any) indicating that I am exempt from FATCA reporting is correct.

Certification instructions. You must cross out item 2 above if you have been notified by the IRS that you are currently subject to backup withholding because you have failed to report all interest and dividends on your tax return. For real estate transactions, item 2 does not apply. For mortgage interest paid, acquisition or abandonment of secured property, cancellation of debt, contributions to an individual retirement arrangement (IRA), and generally, payments other than interest and dividends, you are not required to sign the certification, but you must provide your correct TIN. See the instructions for Part II, later.

Sign Here

Signature of U.S. person

Kimberly J. Conners

Date ▶

9-23-2020

General Instructions

Section references are to the Internal Revenue Code unless otherwise noted.

Future developments. For the latest information about developments related to Form W-9 and its instructions, such as legislation enacted after they were published, go to www.irs.gov/FormW9.

Purpose of Form

An individual or entity (Form W-9 requester) who is required to file an information return with the IRS must obtain your correct taxpayer identification number (TIN) which may be your social security number (SSN), individual taxpayer identification number (ITIN), adoption taxpayer identification number (ATIN), or employer identification number (EIN), to report on an information return the amount paid to you, or other amount reportable on an information return. Examples of information returns include, but are not limited to, the following.

- Form 1099-INT (interest earned or paid)

- Form 1099-DIV (dividends, including those from stocks or mutual funds)
- Form 1099-MISC (various types of income, prizes, awards, or gross proceeds)
- Form 1099-B (stock or mutual fund sales and certain other transactions by brokers)
- Form 1099-S (proceeds from real estate transactions)
- Form 1099-K (merchant card and third party network transactions)
- Form 1098 (home mortgage interest), 1098-E (student loan interest), 1098-T (tuition)
- Form 1099-C (canceled debt)
- Form 1099-A (acquisition or abandonment of secured property)

Use Form W-9 only if you are a U.S. person (including a resident alien), to provide your correct TIN.

If you do not return Form W-9 to the requester with a TIN, you might be subject to backup withholding. See What is backup withholding, later.



3909 RESEARCH PARK DR. SUITE 400 | ANN ARBOR, MI 48108
PHONE 866-919-9578 FAX 734-572-9297 WEB MADSIF.COM

CERTIFICATE OF COVERAGE

POLICY HOLDER

*Wolverine Freightliner - Eastside, Inc.
107 South Groesbeck
Mt Clemens MI 48043*

MAILING ADDRESS

*Wolverine Freightliner - Eastside
3550 Wyoming Ave
Dearborn MI 48120*

COPY OF CERTIFICATE ISSUED TO:

*City of Rochester Hills
1000 Rochester Hills Dr.
Rochester Hills MI 48309*

MADSIF POLICY NUMBER: 380754

This will certify that the company identified above is a participant in good standing with MADSIF and is thereby guaranteed full statutory coverage for workers' disability compensation claims filed under the Michigan Workers' Disability Compensation Act. This coverage is provided through authority granted by the State of Michigan under Chapter 6, Section 418.611(1)(a) of the Workers' Disability Compensation Act.

Effective Date of Coverage: 01/01/2020

Coverage Terminates: 01/01/2021

Part One: Workers Compensation Coverage
Limit: Statutory Limits

Part Two: Employer's Liability Coverage
Limits: \$1,000,000

Insurance Carriers:

MADSIF Self-Insured Retention \$750,000 per Occurrence
Safety National Casualty Corporation excess of MADSIF Self-Insured Retention

Date: September 24, 2020

Timothy E. Roberts
Fund Administrator

Prepared for:
Jason Mach
ROCH HILLS COOP
City of Taylor

Prepared by:
Steven Sexton
WOLVERINE FREIGHTLINER
EASTSIDE INC
107 SOUTH GROESBECK
HIGHWAY
MOUNT CLEMENS, MI 48043
Phone:

A proposal for
ROCH HILLS COOP

Prepared by
WOLVERINE FREIGHTLINER EASTSIDE INC
Steven Sexton

Dec 12, 2025

2027 Freightliner 108SD Plus



Components shown may not reflect all spec'd options and are not to scale

Application Version 12.0.703
Data Version PRL-30D.017
Taylor SA 108SD Plus Plow



12/12/2025 11:10 AM

Page 1 of 19

Prepared for:
 Jason Mach
 ROCH HILLS COOP
 City of Taylor

Prepared by:
 Steven Sexton
 WOLVERINE FREIGHTLINER
 EASTSIDE INC
 107 SOUTH GROESBECK
 HIGHWAY
 MOUNT CLEMENS, MI 48043
 Phone:

D I M E N S I O N S

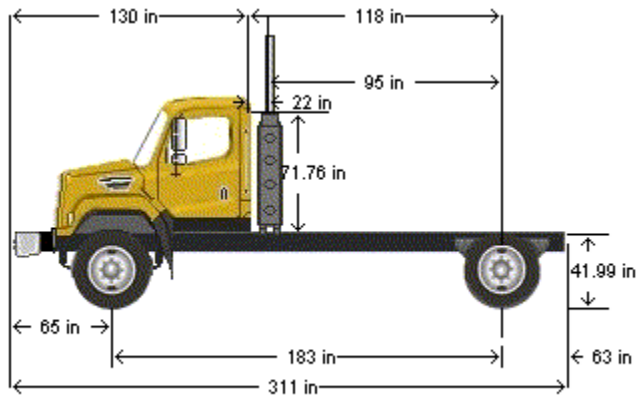

VEHICLE SPECIFICATIONS SUMMARY - DIMENSIONS

Wheelbase (545)	4650MM (183 INCH) WHEELBASE
Rear Frame Overhang (552)	1600MM (63 INCH) REAR FRAME OVERHANG
Fifth Wheel (578)	NO FIFTH WHEEL
Mounting Location (577)	NO FIFTH WHEEL LOCATION
Maximum Forward Position (in)	0
Maximum Rearward Position (in)	0
Amount of Slide Travel (in)	0
Slide Increment (in)	0
Desired Slide Position (in)	0.0
Cab Size (829)	108 INCH BBC FLAT ROOF ALUMINUM CONVENTIONAL CAB
Sleeper (682)	NO SLEEPER BOX/SLEEPER CAB
Exhaust System (016)	RH OUTBOARD FRAME MOUNTED VERTICAL AFTERTREATMENT SYSTEM ASSEMBLY WITH TOPSTACK
Cab to Body Clearance (in)	3.0

TABLE SUMMARY - DIMENSIONS



Prepared for:
 Jason Mach
 ROCH HILLS COOP
 City of Taylor

Prepared by:
 Steven Sexton
 WOLVERINE FREIGHTLINER
 EASTSIDE INC
 107 SOUTH GROESBECK
 HIGHWAY
 MOUNT CLEMENS, MI 48043
 Phone:

Dimensions	Inches
Bumper to Back of Cab (BBC)	130.1
Bumper to Centerline of Front Axle (BA)	64.6
Front Axle to Back of Cab (AC)	65.6
Min. Cab to Body Clearance (CB)	3.0
Back of Cab to Centerline of Rear Axle(s) (CA)	117.5
Effective Back of Cab to Centerline of Rear Axle(s) (Effective CA)	95.1
Back of Cab Protrusions (Exhaust/Intake) (CP)	24.4
Back of Cab Protrusions (Side Extenders/Trim Tab) (CP)	0.0
Back of Cab Protrusions (CNG Tank)	0.0
Back of Cab Clearance (CL)	22.4
Back of Cab to End of Frame	180.5
Cab Height (CH)	71.8
Wheelbase (WB)	183.1
Frame Overhang (OH)	63.0
Overall Frame Length	311.2
Overall Length (OAL)	310.6
Rear Axle Spacing	0.0
Unladen Frame Height at Centerline of Rear Axle	42.0

Performance calculations are estimates only. If performance calculations are critical, please contact Customer Application Engineering.



Prepared for:
 Jason Mach
 ROCH HILLS COOP
 City of Taylor

Prepared by:
 Steven Sexton
 WOLVERINE FREIGHTLINER
 EASTSIDE INC
 107 SOUTH GROESBECK
 HIGHWAY
 MOUNT CLEMENS, MI 48043
 Phone:

S P E C I F I C A T I O N P R O P O S A L

Data Code	Description
Price Level	
PRL-30D	SD PRL-30D (EFF:MY27 ORDERS)
Data Version	
DRL-017	SPECPRO21 DATA RELEASE VER 017
Vehicle Configuration	
001-176	108SD PLUS CONVENTIONAL CHASSIS
004-227	2027 MODEL YEAR SPECIFIED
002-004	SET BACK AXLE - TRUCK
019-006	TRAILER TOWING PROVISION AT END OF FRAME WITH SAE J560
003-001	LH PRIMARY STEERING LOCATION
General Service	
AA1-003	TRUCK/TRAILER CONFIGURATION
AA6-002	DOMICILED, USA 50 STATES (EPA CLEAN IDLE LABEL OR NO CLEAN IDLE REQUIRED)
99D-027	EPA CLEAN IDLE LABEL - (INCLUDES 6X4 INCH LABEL ON LOWER FORWARD OF DRIVER DOOR)
A85-010	UTILITY/REPAIR/MAINTENANCE SERVICE
A84-1GM	GOVERNMENT BUSINESS SEGMENT
AA4-010	DIRT/SAND/ROCK COMMODITY
AA5-002	TERRAIN/DUTY: 100% (ALL) OF THE TIME, IN TRANSIT, IS SPENT ON PAVED ROADS
AB1-008	MAXIMUM 8% EXPECTED GRADE
AB5-001	SMOOTH CONCRETE OR ASPHALT PAVEMENT - MOST SEVERE IN-TRANSIT (BETWEEN SITES) ROAD SURFACE
995-1A0	FREIGHTLINER SD VOCATIONAL WARRANTY
A66-99D	EXPECTED FRONT AXLE(S) LOAD : 16000.0 lbs
A68-99D	EXPECTED REAR DRIVE AXLE(S) LOAD : 23000.0 lbs

Application Version 12.0.703
 Data Version PRL-30D.017
 Taylor SA 108SD Plus Plow



12/12/2025 11:10 AM

Page 4 of 19

Prepared for:
 Jason Mach
 ROCH HILLS COOP
 City of Taylor

Prepared by:
 Steven Sexton
 WOLVERINE FREIGHTLINER
 EASTSIDE INC
 107 SOUTH GROESBECK
 HIGHWAY
 MOUNT CLEMENS, MI 48043
 Phone:

Data Code	Description
A63-99D	EXPECTED GROSS VEHICLE WEIGHT CAPACITY : 39000.0 lbs
A70-99D	EXPECTED GROSS COMBINATION WEIGHT : 80000.0 lbs

Truck Service

AA3-073	BELLY PLOW BODY WITH HIGH GROUND CLEARANCE
AF3-2A8	TRUCK AND TRAILER SPECIALTIES INC.

Engine

101-3BN	CUM L9 300 HP @ 2200 RPM; 2200 GOV RPM, 860 LB-FT @ 1200 RPM
---------	--------------------------------------------------------------

Electronic Parameters

79A-067	67 MPH ROAD SPEED LIMIT
79B-000	CRUISE CONTROL SPEED LIMIT SAME AS ROAD SPEED LIMIT
79K-007	PTO MODE ENGINE RPM LIMIT - 1100 RPM
79L-005	PTO MODE THROTTLE OVERRIDE - LIMIT TO 1100 RPM
79P-004	PTO RPM WITH CRUISE SET SWITCH - 900 RPM
79U-007	PTO GOVERNOR RAMP RATE - 250 RPM PER SECOND
79W-024	CRUISE CONTROL BUTTON PTO CONTROL
79X-036	PTO SPEED 1 SETTING - 875 RPM
80G-007	PTO MINIMUM RPM - 850
80J-002	REGEN INHIBIT SPEED THRESHOLD - 5 MPH
80V-002	ENGINE MOUNT PTO, DASH SWITCH ENGAGES PTO MODE, DRIVING OPERATION

Engine Equipment

99C-024	EPA 2010/GHG 2024 CONFIGURATION
13E-001	STANDARD OIL PAN
105-015	OIL FILL AND DIPSTICK LOCATED FOR ENHANCED SERVICEABILITY
014-1B5	SIDE OF HOOD AIR INTAKE WITH DONALDSON HIGH CAPACITY AIR CLEANER WITH SAFETY ELEMENT, FIREWALL MOUNTED
124-1D7	DR 12V 160 AMP 28-SI QUADRAMOUNT PAD ALTERNATOR WITH REMOTE BATTERY VOLT SENSE
292-206	(3) DTNA GENUINE, FLOODED STARTING, MIN 2850CCA, 525RC, THREADED STUD BATTERIES



Prepared for:
 Jason Mach
 ROCH HILLS COOP
 City of Taylor

Prepared by:
 Steven Sexton
 WOLVERINE FREIGHTLINER
 EASTSIDE INC
 107 SOUTH GROESBECK
 HIGHWAY
 MOUNT CLEMENS, MI 48043
 Phone:

Data Code	Description
290-017	BATTERY BOX FRAME MOUNTED
281-001	STANDARD BATTERY JUMPERS
282-003	SINGLE BATTERY BOX FRAME MOUNTED LH SIDE BACK OF CAB
291-017	WIRE GROUND RETURN FOR BATTERY CABLES WITH ADDITIONAL FRAME GROUND RETURN
289-011	NON-POLISHED BATTERY BOX COVER WITH TETHER
293-058	NON-ESSENTIAL POSITIVE LOAD DISCONNECT, IN CAB CONTROL SWITCH MOUNTED OUTBOARD OF DRIVER SEAT
306-015	PROGRESSIVE LOW VOLTAGE DISCONNECT AT 12.3 VOLTS FOR DESIGNATED CIRCUITS
107-032	CUMMINS TURBOCHARGED 18.7 CFM AIR COMPRESSOR WITH INTERNAL SAFETY VALVE
152-041	ELECTRONIC ENGINE INTEGRAL SHUTDOWN PROTECTION SYSTEM
128-076	CUMMINS ENGINE INTEGRAL BRAKE WITH VARIABLE GEOMETRY TURBO ON/OFF
016-1C0	RH OUTBOARD FRAME MOUNTED VERTICAL AFTERTREATMENT SYSTEM ASSEMBLY WITH TOPSTACK
28F-014	ENGINE AFTERTREATMENT DEVICE, AUTOMATIC OVER THE ROAD REGENERATION AND VIRTUAL REGENERATION REQUEST SWITCH IN CLUSTER
239-026	10 FOOT 06 INCH (126 INCH+0/-5.9 INCH) EXHAUST SYSTEM HEIGHT
237-1CU	RH CURVED TOPSTACK
23U-001	6 GALLON DIESEL EXHAUST FLUID TANK
30N-003	100 PERCENT DIESEL EXHAUST FLUID FILL
23Y-002	DIESEL EXHAUST FLUID PUMP MOUNTED AFT OF DIESEL EXHAUST FLUID TANK
43X-003	LH FORWARD FACE OF DIESEL EXHAUST FLUID TANK 24 TO 28 INCHES BACK OF CAB
43Y-001	STANDARD DIESEL EXHAUST FLUID TANK CAP
242-001	STAINLESS STEEL AFTERTREATMENT DEVICE/MUFFLER/TAILOPIPE SHIELD
273-058	AIR POWERED ON/OFF ENGINE FAN CLUTCH
276-001	AUTOMATIC FAN CONTROL WITHOUT DASH SWITCH, NON ENGINE MOUNTED
110-003	CUMMINS SPIN ON FUEL FILTER
118-008	COMBINATION FULL FLOW/BYPASS OIL FILTER



Prepared for:
 Jason Mach
 ROCH HILLS COOP
 City of Taylor

Prepared by:
 Steven Sexton
 WOLVERINE FREIGHTLINER
 EASTSIDE INC
 107 SOUTH GROESBECK
 HIGHWAY
 MOUNT CLEMENS, MI 48043
 Phone:

Data Code	Description
266-104	1115 SQUARE INCH ALUMINUM RADIATOR
103-039	ANTIFREEZE TO -34F, OAT (NITRITE AND SILICATE FREE) EXTENDED LIFE COOLANT
171-007	GATES BLUE STRIPE COOLANT HOSES OR EQUIVALENT
172-001	CONSTANT TENSION HOSE CLAMPS FOR COOLANT HOSES
270-016	RADIATOR DRAIN VALVE
360-016	1310 ADAPTER FLANGE FOR FRONT PTO PROVISION
138-011	PHILLIPS-TEMRO 1000 WATT/115 VOLT BLOCK HEATER
140-053	BLACK PLASTIC ENGINE HEATER RECEPTACLE MOUNTED UNDER LH DOOR
132-004	ELECTRIC GRID AIR INTAKE WARMER
155-055	DELCO 12V 39MT HD/OCP STARTER WITH THERMAL PROTECTION AND INTEGRATED MAGNETIC SWITCH

Transmission

342-584	ALLISON 3500 RDS AUTOMATIC TRANSMISSION WITH PTO PROVISION
---------	------------------------------------------------------------

Transmission Equipment

343-339	ALLISON VOCATIONAL PACKAGE 223 - AVAILABLE ON 3000/4000 PRODUCT FAMILIES WITH VOCATIONAL MODELS RDS, HS, MH AND TRV
84B-012	ALLISON VOCATIONAL RATING FOR ON/OFF HIGHWAY APPLICATIONS AVAILABLE WITH ALL PRODUCT FAMILIES
84C-023	PRIMARY MODE GEARS, LOWEST GEAR 1, START GEAR 1, HIGHEST GEAR 6, AVAILABLE FOR 3000/4000 PRODUCT FAMILIES ONLY
84D-023	SECONDARY MODE GEARS, LOWEST GEAR 1, START GEAR 1, HIGHEST GEAR 6, AVAILABLE FOR 3000/4000 PRODUCT FAMILIES ONLY
84E-000	PRIMARY SHIFT SCHEDULE RECOMMENDED BY DTNA AND ALLISON, THIS DEFINED BY ENGINE AND VOCATIONAL USAGE
84F-000	SECONDARY SHIFT SCHEDULE RECOMMENDED BY DTNA AND ALLISON, THIS DEFINED BY ENGINE AND VOCATIONAL USAGE
84G-000	PRIMARY SHIFT SPEED RECOMMENDED BY DTNA AND ALLISON, THIS DEFINED BY ENGINE AND VOCATIONAL USAGE



Prepared for:
 Jason Mach
 ROCH HILLS COOP
 City of Taylor

Prepared by:
 Steven Sexton
 WOLVERINE FREIGHTLINER
 EASTSIDE INC
 107 SOUTH GROESBECK
 HIGHWAY
 MOUNT CLEMENS, MI 48043
 Phone:

Data Code	Description
84H-000	SECONDARY SHIFT SPEED RECOMMENDED BY DTNA AND ALLISON, THIS DEFINED BY ENGINE AND VOCATIONAL USAGE
84K-002	2ND GEAR ENGINE BRAKE ALTERNATE PRESELECT WITH MODERATE DOWNSHIFT STRATEGY
84N-011	NEUTRAL AT STOP ENABLED
84U-000	DRIVER SWITCH INPUT - DEFAULT - NO SWITCHES
84V-001	DIRECTION CHANGE ENABLED WITH MULTIPLEXED SERVICE BRAKES - ALLISON 5TH GEN TRANSMISSIONS
353-074	QUICKFIT BODY LIGHTING CONNECTOR UNDER CAB, WITH BLUNTCUTS
34C-011	ELECTRONIC TRANSMISSION WIRING TO CUSTOMER INTERFACE CONNECTOR
341-018	MAGNETIC PLUGS, ENGINE DRAIN, TRANSMISSION DRAIN, AXLE(S) FILL AND DRAIN
345-003	PUSH BUTTON ELECTRONIC SHIFT CONTROL, DASH MOUNTED
97G-004	TRANSMISSION PROGNOSTICS - ENABLED 2013
370-015	WATER TO OIL TRANSMISSION COOLER, IN RADIATOR END TANK
346-003	TRANSMISSION OIL CHECK AND FILL WITH ELECTRONIC OIL LEVEL CHECK
35T-001	ATF-SYNTHETIC AUTOMATIC TRANSMISSION FLUID

Front Axle and Equipment

400-1AA	MERITOR MFS-16-143A 16,000# FL1 71.5 INCH KPI/3.74 INCH DROP SINGLE FRONT AXLE
402-030	MERITOR 16.5X6 Q+ CAST SPIDER CAM FRONT BRAKES, DOUBLE ANCHOR, FABRICATED SHOES
403-002	NON-ASBESTOS FRONT BRAKE LINING
419-023	CONMET CAST IRON FRONT BRAKE DRUMS
427-001	FRONT BRAKE DUST SHIELDS
409-006	FRONT OIL SEALS
408-001	VENTED FRONT HUB CAPS WITH WINDOW, CENTER AND SIDE PLUGS - OIL
416-022	STANDARD SPINDLE NUTS FOR ALL AXLES
405-003	HALDEX AUTOMATIC FRONT SLACK ADJUSTERS



Prepared for:
 Jason Mach
 ROCH HILLS COOP
 City of Taylor

Prepared by:
 Steven Sexton
 WOLVERINE FREIGHTLINER
 EASTSIDE INC
 107 SOUTH GROESBECK
 HIGHWAY
 MOUNT CLEMENS, MI 48043
 Phone:

Data Code	Description
406-001	STANDARD KING PIN BUSHINGS
536-012	TRW TAS-85 POWER STEERING
539-003	POWER STEERING PUMP
534-015	2 QUART SEE THROUGH POWER STEERING RESERVOIR
40T-002	CURRENT AVAILABLE SYNTHETIC 75W-90 FRONT AXLE LUBE

Front Suspension

620-004	16,000# FLAT LEAF FRONT SUSPENSION
619-004	GRAPHITE BRONZE BUSHINGS WITH SEALS - FRONT SUSPENSION
410-001	FRONT SHOCK ABSORBERS

Rear Axle and Equipment

420-051	MERITOR RS-23-160 23,000# R-SERIES SINGLE REAR AXLE
421-563	5.63 REAR AXLE RATIO
424-001	IRON REAR AXLE CARRIER WITH STANDARD AXLE HOUSING
386-074	MXL 176T MERITOR EXTENDED LUBE MAIN DRIVELINE WITH HALF ROUND YOKES
452-001	DRIVER CONTROLLED TRACTION DIFFERENTIAL - SINGLE REAR AXLE
878-018	(1) DRIVER CONTROLLED DIFFERENTIAL LOCK REAR VALVE FOR SINGLE DRIVE AXLE
87B-024	INDICATOR LIGHT FOR EACH DIFFERENTIAL LOCKOUT SWITCH, ENGAGE AT SPEEDS 5 MPH OR LESS, DISENGAGE W/IGN OFF OR SPEEDS EXCEEDING 25 MPH
423-020	MERITOR 16.5X7 Q+ CAST SPIDER CAM REAR BRAKES, DOUBLE ANCHOR, FABRICATED SHOES
433-002	NON-ASBESTOS REAR BRAKE LINING
434-019	ASPHALT SPREADER CLEARANCE REAR BRAKE GEOMETRY
451-023	CONMET CAST IRON REAR BRAKE DRUMS
425-002	REAR BRAKE DUST SHIELDS
440-006	REAR OIL SEALS
426-1B2	BENDIX EVERSURE LONGSTROKE 1-DRIVE AXLE SPRING PARKING CHAMBERS
428-003	HALDEX AUTOMATIC REAR SLACK ADJUSTERS



Prepared for:
 Jason Mach
 ROCH HILLS COOP
 City of Taylor

Prepared by:
 Steven Sexton
 WOLVERINE FREIGHTLINER
 EASTSIDE INC
 107 SOUTH GROESBECK
 HIGHWAY
 MOUNT CLEMENS, MI 48043
 Phone:

Data Code	Description
41T-002	CURRENT AVAILABLE SYNTHETIC 75W-90 REAR AXLE LUBE
42T-001	STANDARD REAR AXLE BREATHER(S)

Rear Suspension

622-1H1	HENDRICKSON PRIMAAX EX 26,000# REAR AIR SUSPENSION
621-125	HENDRICKSON PRIMAAX 10.00" RIDE HEIGHT
431-003	AXLE CLAMPING GROUP
888-077	IGNITION CONTROLLED ELECTRIC DUMP SWITCH FOR AIR SUSPENSION WITH STATE RETENTION
87D-012	REAR AIR SUSPENSION DUMP VALVE AUTOFILL >5 MPH WITH INDICATOR LIGHT
910-004	DUAL AIR REAR SUSPENSION LEVELING VALVES
623-002	TRANSVERSE CONTROL RODS
439-004	REAR SHOCK ABSORBERS - ONE AXLE (AIR RIDE SUSPENSION)

Pusher / Tag Equipment

429-998	NO PUSHER/TAG BRAKE DUST SHIELDS
---------	----------------------------------

Brake System

490-100	WABCO 4S/4M ABS
871-001	REINFORCED NYLON, FABRIC BRAID AND WIRE BRAID CHASSIS AIR LINES
46E-001	STANDARD AIR MANAGEMENT UNIT
904-001	FIBER BRAID PARKING BRAKE HOSE
412-001	STANDARD BRAKE SYSTEM VALVES
46D-002	STANDARD AIR SYSTEM PRESSURE PROTECTION SYSTEM
413-002	STD U.S. FRONT BRAKE VALVE
432-003	RELAY VALVE WITH 5-8 PSI CRACK PRESSURE, NO REAR PROPORTIONING VALVE
480-088	WABCO SYSTEM SAVER HP WITH INTEGRAL AIR GOVERNOR AND HEATER
479-015	AIR DRYER FRAME MOUNTED
460-1AE	STEEL AIR TANKS MOUNTED FOR MAX GROUND CLEARANCE, (BELLY PLOW - AA3-073)
477-004	PULL CABLES ON ALL AIR RESERVOIR(S)

Trailer Connections

476-998	NO AIR HOSE HANGER
---------	--------------------



Prepared for:
 Jason Mach
 ROCH HILLS COOP
 City of Taylor

Prepared by:
 Steven Sexton
 WOLVERINE FREIGHTLINER
 EASTSIDE INC
 107 SOUTH GROESBECK
 HIGHWAY
 MOUNT CLEMENS, MI 48043
 Phone:

Data Code	Description
914-025	AIR CONNECTIONS TO END OF FRAME WITH GLAD HANDS FOR TRUCK AND DUST COVERS
296-025	PRIMARY CONNECTOR/RECEPTACLE WIRED FOR COMBINATION STOP/TURN, CENTER PIN ABS
303-025	SAE J560 7-WAY PRIMARY TRAILER CABLE RECEPTACLE MOUNTED END OF FRAME

Wheelbase & Frame

545-465	4650MM (183 INCH) WHEELBASE
546-102	7/16X3-9/16X11-1/8 INCH STEEL FRAME (11.11MMX282.6MM/0.437X11.13 INCH) 120KSI
548-803	TEM TO EVALUATE AND INSTALL FRAME RAIL REINFORCEMENT AS NEEDED FOR FRONT FRAME MOUNTED EQUIPMENT
552-030	1600MM (63 INCH) REAR FRAME OVERHANG
55W-006	FRAME OVERHANG RANGE: 61 INCH TO 70 INCH
549-002	24 INCH INTEGRAL FRONT FRAME EXTENSION
AC8-99D	CALC'D BACK OF CAB TO REAR SUSP C/L (CA) : 117.52 in
AE8-99D	CALCULATED EFFECTIVE BACK OF CAB TO REAR SUSPENSION C/L (CA) : 95.08 in
AE4-99D	CALC'D FRAME LENGTH - OVERALL : 311.22 in
FSS-0LH	CALCULATED FRAME SPACE LH SIDE : 71.3 in
FSS-0RH	CALCULATED FRAME SPACE RH SIDE : 84.46 in
AM6-99D	CALC'D SPACE AVAILABLE FOR DECKPLATE : 0.0 in
553-001	SQUARE END OF FRAME
587-003	REAR TOW HOOKS
550-001	FRONT CLOSING CROSSMEMBER
559-003	LIGHTWEIGHT HEAVY DUTY ALUMINUM ENGINE CROSSMEMBER
562-001	STANDARD MIDSHIP #1 CROSSMEMBER(S)
572-001	STANDARD REARMOST CROSSMEMBER
565-002	HEAVY DUTY SUSPENSION CROSSMEMBER

Chassis Equipment

556-997	OMIT FRONT BUMPER, CUSTOMER INSTALLED SPECIAL BUMPER, DOES NOT COMPLY WITH FMCSR 393.203
558-001	FRONT TOW HOOKS - FRAME MOUNTED
585-998	NO MUDFLAP BRACKETS



Prepared for:
 Jason Mach
 ROCH HILLS COOP
 City of Taylor

Prepared by:
 Steven Sexton
 WOLVERINE FREIGHTLINER
 EASTSIDE INC
 107 SOUTH GROESBECK
 HIGHWAY
 MOUNT CLEMENS, MI 48043
 Phone:

Data Code	Description
590-998	NO REAR MUDFLAPS
551-002	HUCK-SPIN ROUND COLLAR CHASSIS FASTENERS
44Z-002	EXTERIOR HARNESES WRAPPED IN ABRASION TAPE
Fifth Wheel	
578-998	NO FIFTH WHEEL
Fuel Tanks	
204-215	50 GALLON/189 LITER SHORT RECTANGULAR ALUMINUM FUEL TANK - LH
218-005	RECTANGULAR FUEL TANK(S)
215-005	PLAIN ALUMINUM/PAINTED STEEL FUEL/HYDRAULIC TANK(S) WITH PAINTED BANDS
212-011	FUEL TANK(S) FORWARD - RAISED MOUNTING
664-002	POLISHED STEP FINISH
205-001	FUEL TANK CAP(S)
122-1J1	DETROIT FUEL/WATER SEPARATOR WITH WATER IN FUEL SENSOR, HAND PRIMER AND 12 VOLT PREHEATER"
216-020	EQUIFLO INBOARD FUEL SYSTEM
202-016	HIGH TEMPERATURE REINFORCED NYLON FUEL LINE
Tires	
093-1RJ	MICHELIN X WORKS Z 315/80R22.5 20 PLY RADIAL FRONT TIRES
094-0GP	MICHELIN XDN2 11R22.5 16 PLY RADIAL REAR TIRES
Hubs	
418-060	CONMET PRESET PLUS PREMIUM IRON FRONT HUBS
450-060	CONMET PRESET PLUS PREMIUM IRON REAR HUBS
Wheels	
502-579	MAXION WHEELS 10041 22.5X9.00 10-HUB PILOT 5.25 INSET 5-HAND STEEL DISC FRONT WHEELS
505-545	MAXION WHEELS 90260 22.5X8.25 10-HUB PILOT 2-HAND HD STEEL DISC REAR WHEELS
496-011	FRONT WHEEL MOUNTING NUTS



Prepared for:
 Jason Mach
 ROCH HILLS COOP
 City of Taylor

Prepared by:
 Steven Sexton
 WOLVERINE FREIGHTLINER
 EASTSIDE INC
 107 SOUTH GROESBECK
 HIGHWAY
 MOUNT CLEMENS, MI 48043
 Phone:

Data Code	Description
497-011	REAR WHEEL MOUNTING NUTS
Cab Exterior	
829-1A5	108 INCH BBC FLAT ROOF ALUMINUM CONVENTIONAL CAB
650-008	AIR CAB MOUNTING
648-002	NONREMOVABLE BUGSCREEN MOUNTED BEHIND GRILLE
667-037	SHORT FENDER WITH MUDFLAP
754-017	BOLT-ON MOLDED FLEXIBLE FENDER EXTENSIONS
678-001	LH AND RH GRAB HANDLES
645-002	BRIGHT FINISH RADIATOR SHELL/HOOD BEZEL
646-042	STATIONARY BLACK GRILLE WITH BRIGHT ACCENTS
65X-003	CHROME HOOD MOUNTED AIR INTAKE GRILLE
644-006	FIBERGLASS HOOD WITH ACCESS HATCHES
652-001	FREIGHTLINER NAME PLATES
690-002	TUNNEL/FIREWALL LINER
727-066	DUAL 26 INCH RECTANGULAR POLISHED ALUMINUM AIR HORNS ROOF MOUNTED
726-001	SINGLE ELECTRIC HORN
728-002	DUAL HORN SHIELDS
312-067	HALOGEN COMPOSITE HEADLAMPS WITH BRIGHT BEZELS
302-074	SMALL LED AERODYNAMIC MARKER LIGHTS WITH OUTER (2) WIRED TO BATTERY DISCONNECT SWITCH
314-824	WIRING AND SWITCH FOR CUSTOMER FURNISHED SNOW PLOW LAMPS WITH DUAL CONNECTIONS AT BUMPER
311-001	DAYTIME RUNNING LIGHTS
294-1AY	INTEGRAL LED STOP/TAIL/BACKUP LIGHTS
300-015	STANDARD FRONT TURN SIGNAL LAMPS
744-1BC	DUAL WEST COAST BRIGHT FINISH HEATED MIRRORS WITH LH AND RH REMOTE
797-001	DOOR MOUNTED MIRRORS
796-001	102 INCH EQUIPMENT WIDTH
743-204	LH AND RH 8 INCH BRIGHT FINISH CONVEX MIRRORS MOUNTED UNDER PRIMARY MIRRORS
729-001	STANDARD SIDE/REAR REFLECTORS



Prepared for:
 Jason Mach
 ROCH HILLS COOP
 City of Taylor

Prepared by:
 Steven Sexton
 WOLVERINE FREIGHTLINER
 EASTSIDE INC
 107 SOUTH GROESBECK
 HIGHWAY
 MOUNT CLEMENS, MI 48043
 Phone:

Data Code	Description
677-062	FIXED CAB MOUNTED STEPS LH AND RH FOR CAB ENTRY, BELLY PLOW BODY WITH HIGH GROUND CLEARANCE DOES NOT COMPLY FMCSR 399
768-043	63X14 INCH TINTED REAR WINDOW
661-004	TINTED DOOR GLASS LH AND RH WITH TINTED OPERATING WING WINDOWS
654-011	RH AND LH ELECTRIC POWERED WINDOWS
663-029	1-PIECE BONDED HEATED WIPER PARK SOLAR GREEN GLASS WINDSHIELD
659-007	8 LITER (2 GAL) WINDSHIELD WASHER RESERVOIR, CAB MOUNTED, WITHOUT FLUID LEVEL INDICATOR

Cab Interior

055-018	ELITE TRIM PACKAGE
707-106	MIST CLOTH & CARBON VINYL INTERIOR "ELITE"
70K-019	CARBON WITH PREMIUM WOOD ACCENT (ELITE)
706-013	MOLDED DOOR PANEL
708-013	MOLDED PLASTIC DOOR PANEL
772-006	BLACK MATS WITH SINGLE INSULATION
785-026	(1)DASH MOUNTED 12V POWER OUTLET, (1)DASH MOUNTED DUAL USB-C OUTLET
691-001	FORWARD ROOF MOUNTED CONSOLE
696-012	CENTER STORAGE CONSOLE MOUNTED ON BACKWALL
693-035	LH AND RH KICKPLATES
738-021	DIGITAL ALARM CLOCK IN DRIVER DISPLAY
742-007	(2) CUP HOLDERS LH AND RH DASH
680-029	M2/SD DASH
700-002	HEATER, DEFROSTER AND AIR CONDITIONER
701-001	STANDARD HVAC DUCTING
703-005	MAIN HVAC CONTROLS WITH RECIRCULATION SWITCH
170-015	STANDARD HEATER PLUMBING
130-041	VALEO HEAVY DUTY A/C REFRIGERANT COMPRESSOR
702-002	BINARY CONTROL, R-134A
739-033	STANDARD INSULATION



Prepared for:
 Jason Mach
 ROCH HILLS COOP
 City of Taylor

Prepared by:
 Steven Sexton
 WOLVERINE FREIGHTLINER
 EASTSIDE INC
 107 SOUTH GROESBECK
 HIGHWAY
 MOUNT CLEMENS, MI 48043
 Phone:

Data Code	Description
285-013	SOLID-STATE CIRCUIT PROTECTION AND FUSES
280-007	12V NEGATIVE GROUND ELECTRICAL SYSTEM
324-1B3	STANDARD LED CAB LIGHTING
787-998	NO SECURITY DEVICE
657-1AW	ALL UNIT(S) KEYED ALIKE WITH CUSTOMER SPECIFIED KEY NUMBER FT1010
78G-004	KEY QUANTITY OF 4
655-005	LH AND RH ELECTRIC DOOR LOCKS
740-998	NO MATTRESS
756-339	PREMIUM ISRINGHAUSEN HIGH BACK AIR SUSPENSION DRIVERS SEAT WITH 2 AIR LUMBAR, INTEGRATED CUSHION EXTENSION, TILT AND ADJUSTABLE SHOCK
760-335	BASIC ISRI HIGH BACK NON SUSPENSION PASSENGER SEAT
759-007	DUAL DRIVER SEAT ARMRESTS, NO PASSENGER SEAT ARMRESTS
711-004	LH AND RH INTEGRAL DOOR PANEL ARMRESTS
758-022	BLACK MORDURA CLOTH DRIVER SEAT COVER
761-023	BLACK MORDURA CLOTH PASSENGER SEAT COVER
763-104	HIGH VISIBILITY ORANGE SEAT BELTS WITH DRIVER INDICATOR LIGHT AND AUDIBLE ALARM
532-002	ADJUSTABLE TILT AND TELESCOPING STEERING COLUMN
540-070	4-SPOKE 18 INCH (450MM) LEATHER WRAPPED STEERING WHEEL WITH CHROME SWITCH BEZELS
765-002	DRIVER AND PASSENGER INTERIOR SUN VISORS

Instruments & Controls

*	4CH-006	6 EXTRA PROGRAMMABLE SWITCHES/INDICATORS \$C1B0208ZZ,C1C0209ZZ,C1D0200ZZ,C1E0205ZZ,C4U0214ZZ,C1F0072ZZ
	106-002	ELECTRONIC ACCELERATOR CONTROL
	732-998	NO INSTRUMENT PANEL-DRIVER
	734-022	FULLY CONFIGURABLE CENTER INSTRUMENT PANELS
	87L-001	ENGINE REMOTE INTERFACE WITH PARK BRAKE INTERLOCK



Prepared for:
 Jason Mach
 ROCH HILLS COOP
 City of Taylor

Prepared by:
 Steven Sexton
 WOLVERINE FREIGHTLINER
 EASTSIDE INC
 107 SOUTH GROESBECK
 HIGHWAY
 MOUNT CLEMENS, MI 48043
 Phone:

Data Code	Description
870-002	BRIGHT ARGENT FINISH GAUGE BEZELS
486-001	LOW AIR PRESSURE INDICATOR LIGHT AND AUDIBLE ALARM
840-001	DUAL NEEDLE PRIMARY AND SECONDARY AIR PRESSURE GAUGE
198-003	DASH MOUNTED AIR RESTRICTION INDICATOR WITH GRADUATIONS
149-015	ELECTRONIC CRUISE CONTROL WITH CONTROLS ON STEERING WHEEL SPOKES
156-007	KEY OPERATED IGNITION SWITCH AND INTEGRAL START POSITION; 4 POSITION OFF/RUN/START/ACCESSORY
811-044	PREMIUM INSTRUMENT CLUSTER WITH 5.0 INCH TFT COLOR DISPLAY
81B-003	DIGITAL PANEL LAMP DIMMER SWITCH IN DRIVER DISPLAY
160-038	HEAVY DUTY ONBOARD DIAGNOSTICS INTERFACE CONNECTOR LOCATED BELOW LH DASH
844-001	2 INCH ELECTRIC FUEL GAUGE
148-072	ENGINE REMOTE INTERFACE WITH ONE OR MORE SET SPEEDS
48H-001	QUICKFIT POWERTRAIN INTERFACE CONNECTOR LOCATED BETWEEN SEATS WITH CAPS
48C-002	QUICKFIT PROGRAMMABLE INTERFACE CONNECTOR(S) BETWEEN SEATS WITH BLUNTCUTS
163-014	ENGINE REMOTE INTERFACE CONNECTOR AT POWERTRAIN INTERFACE CONNECTOR
856-001	ELECTRICAL ENGINE COOLANT TEMPERATURE GAUGE
852-002	ELECTRIC ENGINE OIL PRESSURE GAUGE
864-001	2 INCH TRANSMISSION OIL TEMPERATURE GAUGE
867-004	ELECTRONIC OUTSIDE TEMPERATURE SENSOR DISPLAY IN DRIVER MESSAGE CENTER
830-017	ENGINE AND TRIP HOUR METERS INTEGRAL WITHIN DRIVER DISPLAY
372-123	PTO CONTROLS FOR ENHANCED VEHICLE ELECTRIC/ELECTRONIC ARCHITECTURE
736-998	NO OBSTACLE DETECTION SYSTEM
72J-998	NO DR ASSIST SYSTEM



Prepared for:
 Jason Mach
 ROCH HILLS COOP
 City of Taylor

Prepared by:
 Steven Sexton
 WOLVERINE FREIGHTLINER
 EASTSIDE INC
 107 SOUTH GROESBECK
 HIGHWAY
 MOUNT CLEMENS, MI 48043
 Phone:

Data Code	Description
49B-998	NO VEHICLE STABILITY ADVISOR OR CONTROL
73B-998	NO LANE DEPARTURE WARNING SYSTEM
679-023	CENTER OVERHEAD INSTRUMENT PANEL BLANK
35M-011	1 QUIKFIT PROGRAMABLE MODULE (QPM/XMC) W/ (4) 20AMP FUSED RELAYS
746-143	7" B-PANEL INTERACTIVE TOUCHSCREEN DISPLAY RADIO W/ USB-C, APPLE CARPLAY, ANDROID AUTO, BLUETOOTH/AM/FM/SXM/WB, WITH MICROPHONE
747-001	DASH MOUNTED RADIO
750-002	(2) RADIO SPEAKERS IN CAB
753-001	AM/FM ANTENNA MOUNTED ON FORWARD LH ROOF
749-998	NO CB RADIO MOUNTING PROVISION
75W-998	NO MULTIBAND ANTENNA
78C-004	INTEROPERABLE SDAR ANTENNA, SHIP LOOSE
810-027	ELECTRONIC MPH SPEEDOMETER WITH SECONDARY KPH SCALE, WITHOUT ODOMETER
817-001	STANDARD VEHICLE SPEED SENSOR
812-001	ELECTRONIC 3000 RPM TACHOMETER
813-1C8	DETROIT CONNECT PLATFORM HARDWARE
8D1-313	3 YEARS DAIMLER CONNECTIVITY BASE PACKAGE ON (FEATURES VARY BY MODEL) POWERED BY DETROIT CONNECT ON CUMMINS ENGINES
8D4-998	NO FUEL SYSTEMS DATA SERVICE(SCO)
6TS-005	TMC RP1226 ACCESSORY CONNECTOR LOCATED BEHIND PASSENGER SIDE REMOVEABLE DASH PANEL
162-002	IGNITION SWITCH CONTROLLED ENGINE STOP
329-110	ONE EXTRA HARDWIRED SWITCH IN DASH, ROUTE TO UNDER CAB, CAPPED
4C1-026	HARDWIRE SWITCH #1, ON/OFF LATCHING, 10 AMPS BATTERY POWER
81Y-005	PRE-TRIP INSPECTION FEATURE FOR EXTERIOR LAMPS ONLY
264-030	(1) OVERHEAD MOUNTED LANYARD CONTROL FOR DRIVER AIR HORN
482-001	STANDARD TRACTOR PROTECTION VALVE
883-001	TRAILER HAND CONTROL BRAKE VALVE



Prepared for:
 Jason Mach
 ROCH HILLS COOP
 City of Taylor

Prepared by:
 Steven Sexton
 WOLVERINE FREIGHTLINER
 EASTSIDE INC
 107 SOUTH GROESBECK
 HIGHWAY
 MOUNT CLEMENS, MI 48043
 Phone:

Data Code	Description
836-015	DIGITAL VOLTAGE DISPLAY INTEGRAL WITH DRIVER DISPLAY
660-008	SINGLE ELECTRIC WINDSHIELD WIPER MOTOR WITH DELAY
304-030	ROTARY HEADLAMP SWITCH, MARKER LIGHTS/HEADLIGHTS SWITCH WITH PULL OUT FOR OPTIONAL FOG/ROAD LAMPS
882-004	TWO VALVE PARKING BRAKE SYSTEM WITH WARNING INDICATOR
299-020	SELF CANCELING TURN SIGNAL SWITCH WITH DIMMER, HEADLAMP FLASH, WASH/WIPE/INTERMITTENT
298-046	INTEGRAL ELECTRONIC TURN SIGNAL FLASHER WITH 40 AMP (20 AMP PER SIDE) TRAILER LAMP CAPACITY
87T-998	NO WRG/SW-OPTL #2,CHAS,AIR

Design

065-000	PAINT: ONE SOLID COLOR
---------	------------------------

Color

980-6H9	CAB COLOR A: L3258EY SEMI YELLOW ELITE EY
986-020	BLACK, HIGH SOLIDS POLYURETHANE CHASSIS PAINT
962-972	POWDER WHITE (N0006EA) FRONT WHEELS/RIMS (PKWHT21, TKWHT21, W, TW)
966-972	POWDER WHITE (N0006EA) REAR WHEELS/RIMS (PKWHT21, TKWHT21, W, TW)
963-003	STANDARD E COAT/UNDERCOATING

Certification / Compliance

996-001	U.S. FMVSS CERTIFICATION, EXCEPT SALES CABS AND GLIDER KITS
---------	-------------------------------------------------------------

Secondary Factory Options

999-063	DEALER ADVISED/ACCEPTS ESC ON END OF FRAME TOWING FOR TRACTOR FOR YARD HAUL USE
---------	---------------------------------------------------------------------------------

Extended Warranty

WAI-47H	CUM 2017 L9: HD1 MD DTY 5 YEARS / 100,000 MILES / 161,000 KM EXTENDED WARRANTY. FEX APPLIES
WAX-101	CUM 2017 L9: AT3 MD DTY 5 YEARS / 100,000 MILES / 161,000 KM AFTERTREATMENT. FEX APPLIES



Prepared for:
Jason Mach
ROCH HILLS COOP
City of Taylor

Prepared by:
Steven Sexton
WOLVERINE FREIGHTLINER
EASTSIDE INC
107 SOUTH GROESBECK
HIGHWAY
MOUNT CLEMENS, MI 48043
Phone:

WAD-078 EXT COOLING COMPLETE: MD STANDARD-MODERATE 5
YEARS/100,000 MILES/161,000 KM

WAK-252 ALLISON 3500 RDS SERIES TRANSMISSION EXTEND WARRANTY, 5
YEARS/UNLIMITED MILES FEX

WAG-075 TOWING: 2 YEARS/UNLIMITED MILES/KM EXTENDED TOWING
COVERAGE \$750 CAP FEX APPLIES

(***) All cost increases for major components (Engines, Transmissions, Axles, Front and Rear Tires) and government mandated requirements, tariffs, and raw material surcharges will be passed through and added to factory invoices.



CITY OF TAYLOR

Timothy Woolley
MAYOR

Cynthia A. Bower
CLERK

Nicone Dragone Sr.
TREASURER



23555 Goddard Road
Taylor, MI 48180
(734) 287 6550
www.cityoftaylor.com

COUNCIL

Charley Johnson
CHAIRMAN

Ron Thiede
CHAIR PRO-TEM

Christian Armstrong
Chris Clark
William Patts
Gerald P. Thomas
Dan Wallace

To: Honorable Mayor and City Council
From: Ben Clayton, Purchasing Manager
Date: 2/3/2026
Subject: Support for Agenda Item DPW Dump Truck

To Whom It May Concern,

The Purchasing Department has completed a comprehensive review of the referenced agenda item. After full evaluation, we have determined that the request meets the requirements outlined in the City of Taylor Purchasing Policies and Procedures.

This request has been fully vetted and complies with all applicable guidelines within the City of Taylor Purchasing Policies. Accordingly, it is supported for inclusion on the February 3, 2026 City Council meeting agenda.

Best regards,

Ben Clayton Jr. MA, MPM
Purchasing Manager
City of Taylor



ETNA SUPPLY - GRAND RAPIDS
 4901 CLAY AVENUE SW
 GRAND RAPIDS MI 49548-3038
 616 241 5414 Fax 616 241 4786

INVOICE

TO VIEW ONLINE GO TO:	etna.billtrust.com
USE THIS ENROLLMENT TOKEN:	LDT FPT VQV
USE THIS ACCOUNT NUMBER:	9560

INVOICE DATE	INVOICE NUMBER	
01/23/26	S106695643.001	
REMIT TO:		PAGE
ETNA SUPPLY PO BOX 772107 DETROIT MI 48277-2107		1 of 1

BILL TO:

SHIP TO:

CITY OF TAYLOR
 23555 GOODARD RD
 TAYLOR MI 48180-4116

CITY OF TAYLOR
 25605 NORTHLINE
 TAYLOR MI 48180-4116

CUSTOMER NUMBER	PURCHASE ORDER NUMBER	JOB NAME / RELEASE NUMBER	SALESPERSON		
9560	ANNUAL HOSTING		Jason McClanahan		
WRITER	SHIP VIA	TERMS	SHIP DATE	ORDER DATE	
Rolly Olney	DIRECT	NET 25TH	01/23/26	01/23/26	
ORDER QTY	SHIP QTY	UOM	DESCRIPTION	UNIT PRICE	EXT PRICE
1	1	ea	^SENSUS ANNUAL RNI HOSTING FEE - 2/19/26 - 2/18/27 *Nonstock - Restock Policy Applies*	19700.000E	19700.00
1	1	ea	^SENSUS ANNUAL ANALYTICS ENHANCED HOSTING FEE - 2/19/26 - 2/18/27 *Nonstock - Restock Policy Applies*	19700.000E	19700.00

Invoice is due by 02/25/26.

This Invoice is controlled by Seller's standard terms and conditions of sale found at www.etnasupply.com/tcsale. All other terms are expressly rejected.

Past due invoices may be subject to a 1.70% Time Price Differential.

SUBTOTAL	39,400.00
S&H CHARGES	0.00
TAX	0.00
PAYMENTS	0.00
AMOUNT DUE	39,400.00

CITY OF TAYLOR SOLE SOURCE JUSTIFICATION FORM

INSTRUCTIONS: Complete this entire form, including BOTH SECTIONS I and II for all sole source purchases. Send the completed form to the Budget & Finance Department, Central Purchasing. In compliance with Section 4.12 of the City of Taylor Purchasing Policy, this document shall accompany any sole source request to the City Council as part of council package for review and consideration. Failure to provide the requested information and supporting documentation will most likely result in postponement.

If you have any questions, or need additional assistance, contact the Purchasing Office at 734.374.1459 or 734.374.1396. Information is also available at <http://www.cityoftaylor.com/purchasing>.

NOTE:

- 1. Price is never a basis for a sole source request.
- 2. Supporting documentation must accompany this form.

Requisition Title (or) #: ETNA Supply Hosting Fee
 Commodity/service being purchased: Annual Hosting Proposed purchase price: \$ 39,400.00
 Proposed / Requested Supplier: ETNA Supply
 Requested by: Jason Mach Department: Water Billing Contractual service
 Date: 01/08/2026 Email/phone #: jmach@cityoftaylor.mi.gov
 Sole source justification prepared by: Jason Mach

I. SOLE SOURCE JUSTIFICATION

1. A Sole Source Purchase is available from only one supplier and meets at least one of the following criteria (please check the appropriate boxes):

- One-of-a-kind- The commodity or service has no competitive product alternatives on the market.
- Compatibility - The commodity or service matches existing brand of equipment for compatibility.
- Replacement part - The commodity is a replacement part for a specific brand of existing equipment.
- Unique design - The commodity or service meets physical design or quality requirements.
- Professional Service - The service falls under the Purchasing Policy Professional Service Section 4.10.

If any of the above apply – Are you aware of other sources (other than the one requested) that could offer the exact brand or service, such as a distributor, third party broker, or reseller? If so, please list possible sources.

OR

- Delivery date - ONLY ONE SUPPLIER can meet necessary delivery date requirement for the required quantity on ___.
- Emergency - URGENT NEED for the item or service does not permit soliciting competitive bids, as in cases of emergencies, disaster, etc., which was required on _____

2. Briefly explain what it is about this product or service that only this vendor can meet: _____

Annual Hosting Fee For the 2 Each Radio Towers that read the water meters For Billing

CITY OF TAYLOR SOLE SOURCE JUSTIFICATION FORM

3. Indicate if the product or service has been purchased for this department in the past, the approximate date of purchase, and purchase order number, if known: 4/14/25, CCR 4.122-25, PO. 24710
4. List the specific important features or specific performance specifications or parameters that make this product or service unique or proprietary, AND indicate specifically why these unique features are important to your department operations: — Meter Reading and Billing Compatibility
5. List other suppliers generally believed to offer the same or very similar product or service. Indicate if they were contacted for a description and/or price of their product or service. If they were not contacted, indicate why they were omitted. Indicate for each specifically why their product or service is judged to be unacceptable.
- a) None
- b) _____
- c) _____

II. DOCUMENTATION OF PRICE REASONABLENESS

Check the box(es) that apply and provide information:

1. I determined that the price is reasonable for one of the following reasons:
- (a) I compared the proposed price to prices I previously paid for the same or similar goods and/or services. See PO# (Specify price: \$) _____
- (b) I compared the proposed price to current published catalog, price lists, or market prices as documented in the attachments (attach relevant documentation) and the proposed price is less.
- (c) I compared the proposal price to similar benchmarks, (e.g., dollars per pound, horsepower, or other units of measure) to identify any gross inconsistencies. Describe comparisons made: _____
- (d) Based on my knowledge of the market, my experience of prior similar proposals. Describe basis of market knowledge or reference prior proposals: _____
- (e) The price is set by law or regulations. Provide reference to law or regulation: _____
- (f) The goods or services are available on the market for the same or similar price. Provide reference to market pricing information: _____
2. Sections 1 (a) through (f) do not apply. (Purchasing will contact you to discuss price reasonableness before a requisition can be processed.)

CITY OF TAYLOR SOLE SOURCE JUSTIFICATION FORM

III. CONFLICT OF INTEREST STATEMENT

The Requestor agrees that there is no real or potential Conflict of Interest in recommending this product and/or service as a Sole Source procurement. (NOTE: If you do have a real or potential conflict of interest, please contact the appropriate Purchasing Agent.)

As the authorized department official, I certify that the above justification is accurate and complete to the best of my knowledge and belief.

Approval:



Signature of Department Head

11/28/26
Date

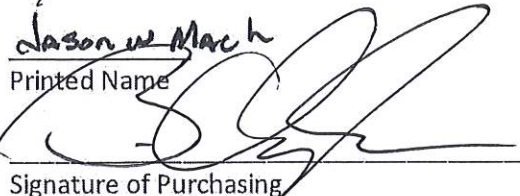
Jason W March
Printed Name

Signature of Purchasing

11-28-26
Date

Ben Clayton
Printed Name Purchasing MGR

***Lease Agreement Between the City of Taylor
and Rosecrans Picture Perfect***

- (1) This Lease made this 1st day of December, 2025, by and between The City of Taylor, a Michigan Municipal Corporation, 23555 Goddard Road, Taylor Michigan, 48180, as Lessor, hereinafter designated as "City", and Mary Rosecrans, DBA Rosecrans Picture Perfect, a s Lessee, hereinafter designated as "Tenant".
- (2) The City, in consideration of the rents to be paid and the covenants and agreements to be performed by the Tenant; does hereby lease unto the Tenant the following described premises situated in the City of Taylor, County of Wayne, State of Michigan. The building is designated as the Schonscheck House, in the City of Taylor, Heritage Park Historic Village, House number 12405 Pardee Rd.
- (3) For the term beginning December 1, 2025 and continuing through November 30, 2030, the Tenant shall pay during the continuance of this lease unto the City for the rent of said premises for the following amounts; the sum of \$1,000.00 per month for the first year, \$1,040 per month for the second year, \$1,082 per month for the third year, \$1,125 per month for the fourth year, and \$1,170 per month for the fifth year, payable in advance, prior to the first of each month. Rent payments made after the first of the month will be subject to a \$100 late fee for every 30 days such payment is late. If either party wishes to terminate this lease a ninety-day written notice of termination must be given as provided in Section 35.
- (4) The Tenant hereby leases the said premise for the said term as above mentioned and covenants to pay or cause to be paid unto the City at the date and times mentioned, the rent above reserved.
- (5) If the Tenant should default in any payment or expenditure other than rent required to be paid or extended by the Tenant under the terms hereof, the City may, at its option, make such payment or expenditure, in which event the amount thereof shall be payable as additional rent to the City by the Tenant on the next ensuing rent day together with interest at 10% per annum from the date of such payment or expenditure by the City and on default in such payment the City shall have the same remedies as on default in payment of rent.
- (6) All payments of rent shall be made to the City at The Taylor Recreation Center 22805 Goddard Road, Taylor, MI 48180
- (7) The Tenant covenants not to assign or transfer this lease or mortgage the premises or sublet said premises or any part thereof without written consent of the City. Any assignment, transfer, mortgage or subletting without said written consent shall give the City the right to terminate their lease and to reenter and repossess the leased premises. Tenant may assign this lease under the same terms as set forth herein upon written approval of the City.
- (8) The Tenant agrees that if the estate created hereby shall be taken in execution, or by other process of law, or if the Tenant shall be declared bankrupt or insolvent, according to law, or any receiver by appointed for the business and property of the Tenant, or if any assignment shall be made of the Tenant's property for the benefit of creditors, then and in such event this lease may be cancelled immediately at the option of the City.
- (9) The City reserves the right to subject and subordinate this lease at all times to the lien of any mortgage now or hereafter placed upon the City's interest in the

said premises and on the land and buildings of the said premises are a part or upon any buildings hereafter placed upon the land of which the leased premises form a part. And the Tenant covenants and agrees to execute and deliver upon demand such further instruments subordinating this lease to the lien of any such mortgage or mortgages as shall be desired by the City and any mortgages or proposed mortgages and hereby irrevocably appoints the City the attorney-in-fact of the Tenant to execute and deliver any such instrument or instruments for and in the name of the Tenant.

- (10) It is understood and agreed between parties hereto that said premises during the continuance of the lease shall be used and occupied by Tenant solely for photography and related services and products such as frames, photo restoration, videography, wedding related services, etc., and for no other purpose or purposes without the written consent of the City. Tenant shall not keep or board any animals on the premises. Pets of customers are permitted for photographs but shall not remain on the premises except during the photography session. Tenant shall not conduct any "special events", other than an annual Easter Egg Hunt, without written approval of the City and the Tenant will not use the premises for any purpose in violation of any law, municipal ordinance or regulation, and that on any breach of this agreement the City may at his option terminate this lease immediately and reenter and repossess the leased premises.
- (11) It is understood and agreed that if the premises hereby leased be damaged or destroyed in whole or in part by fire or other casualty during the term hereof, the City will repair and restore the same to good tenantable condition with reasonable dispatch, and that the rent herein provided for shall abate entirely in case the entire premises are untenable and prorated for the portion rendered tenantable, in case a part is only tenantable, until the same shall be restored to a tenantable condition; provided, however, that if the Tenant shall fail to adjust his own insurance or to remove his damaged goods, wares, equipment or property within a reasonable time, and as a result thereof the repairing and restoration is delayed, there shall be no abatement or rental if such fire or other cause damaging or destroying the leased premises shall result from the negligence or willful act of the Tenant, his agents or employees, and provided further that if the Tenant shall use any part of the leased premises for storage during the period of repair a reasonable charge shall be made therefore against the Tenant, and provided further that in case the leased premises, or the building of which they are a part, shall be destroyed to the extent of more than one-half of the value thereof, the City may at his option terminate this lease forthwith by written notice to the Tenant.
- (12) In the event the City sells the current premises and purchases a new building, this agreement may continue, upon mutual agreement, between the City and the Lessee and the current rent shall be renegotiated and agreed upon by said parties.
- (13) The City after receiving written notice from the Tenant and having reasonable opportunity thereafter to obtain the necessary workmen therefore agrees to keep in good order and repair the roof and the four walls of the premises.
- (14) The Tenant agrees to indemnify, hold harmless and defend the City from any liability for damages or injury to any person or property in, on about said leased premises from any cause whatsoever, including all City costs and attorney fees; and Tenant will procure and keep in effect during the term hereof public liability and property damage insurance for the benefit of the city as outlined in City of Taylor Insurance Requirements (attached), and maintain said coverage according to these standards. Tenant shall deliver said policies to the City and upon Tenant's failure to do so the City may at their option obtain such insurance and the cost thereof shall be paid as additional rent due and payable upon the next ensuing rent day. The City of Taylor written insurance requirements are deemed to be a part of this Agreement and are incorporated herein by reference.
- (15) The Tenant further covenants and agrees that she will, at her own expense,

during the continuation of this lease, keep the said premises and every part thereof in as good repair and at the expiration of the term yield and deliver up the same in like condition as when taken, reasonable use and wear thereof and damage by the elements excepted. The Tenant shall not, without written consent of the City, make any alterations, additions or improvements to or upon the premises, except movable office furniture and trade fixtures put in at the expense of the Tenant. Any improvements shall be the property of the City and shall remain upon and be surrendered with the premises at the termination of this lease.

- (16) In the event any Federal, State or Local entity takes property by eminent domain, this lease shall automatically be terminated,
- (17) The City reserves the right of free access at all times to said leased premises and reserves the right to use portions of the leased premises advertising purposes. The Tenant shall not erect any structures for any purpose without consent in writing of the City. The City will notify the Tenant at least 24 hours prior to entry into the premises as a courtesy to the Tenant.
- (18) The Tenant shall not perform any acts or carry on any practices which may damage the building or leased premises or be a nuisance to other Tenants or patrons in the building and shall keep premises under her control (including adjoining drives, streets, alleys or yard) clean and free from rubbish, dirt, snow and ice at all times, and it is further agreed that in the event the Tenant shall not comply with these provisions, the City may enter upon said premises and have rubbish, dirt and ashes removed and the sidewalks cleaned, in which event the Tenant agrees to pay all charges that the City shall pay for hauling rubbish, dirt and ashes, or cleaning walks. Said charges shall be paid to the City by the Tenant as soon as the bill is presented to him and the City shall have the same remedy as is provided in Paragraph 5 of this lease in the event of Tenant's failure to pay.
- (19) The Tenant shall at his own expense under penalty of forfeiture and damages promptly comply with all lawful laws, orders, regulations, licensing or ordinances of all municipal, county and state authorities affecting the premises hereby leased and the cleanliness, safety, occupation and use of same.
- (20) The Tenant further acknowledges that he has examined the said leased premises prior to the making of this lease, and knows the condition thereof, and that no representations as to the condition or state or repairs thereof have been made by the City, or their agent, which are not herein expressed, and the Tenant hereby accepts the leased premises in their present condition at the date of the execution of this lease.
- (21) The City shall not be responsible or liable to the Tenant for any loss or damage that may be occasioned by or through the acts or omissions of persons occupying adjoining premises or any part of the premises adjacent to or connected with the premises hereby lease or any part of the building of which the leased premises are a part or for any loss or damage resulting to the Tenant or his property from bursting, stoppage, or leaking of water, gas, sewer or steam pipes.
- (22) The Tenant hereby agrees that for a period commencing 90 days prior to the termination of this lease, the City may show the premises to prospective Tenants, and 60 days prior to the termination of this lease, may display in and about said premises and in the windows thereof, the usual and ordinary "To Rent" signs.
- (23) It is hereby agreed that in the event of the Tenant herein holding over after the termination of this lease, thereafter the tenancy shall be from month to month in the absence of a written agreement to the contrary.
- (24) The Tenant will pay all charges made against said lease premises for gas, heat, electricity and telephone during the term of this lease, and any

continuance thereof, as the same shall become due.

- (25) It is further agreed that all signs and advertising displayed in and about the premises shall be as approved by the City and only to advertise the business carried on upon said premises, and that the City shall control the character and size thereof, and that no sign shall be displayed excepting as shall be approved in writing by the City. The City does not allow extended use of lawn signs or banners. All special event advertising must get prior approval from the Parks and Recreation Department.
- (26) The City shall have the right to enter the leased premises at all reasonable hours for the purpose of inspecting the same. The City will provide at least 24 hour prior notice of such entry as a courtesy to the Tenant, however, in the event of an emergency on the premises, the City may enter the premises without notice. If the City deems any repairs necessary, City may demand that the Tenant make the same and if the Tenant refuses or neglects forthwith to commence such repairs and complete the same with reasonable dispatch, the City may make or cause to be made such repairs and shall not be responsible to the Tenant for any loss or damage that may accrue to his stock or business by reason thereof, and if the City makes or causes to be made such repairs the Tenant agrees that he will forthwith on demand pay to the City the cost thereof with at 10% per annum and if Tenant shall make default in such payment, the City shall have the remedies provided in Paragraph 5 hereof.
- (27) In case any rent shall be due and unpaid or if default be made in any of the covenants herein contained, or if said leased premises shall be deserted or vacated, then it shall be lawful for the City or its agents and representatives and assigns, to reenter into, repossess the said premises and the Tenant and each and every occupant shall immediately vacate the premises. The City covenants that the said Tenant, on payment of all the aforesaid installments and performing all the covenants aforesaid, shall and may peacefully and quietly have, hold and enjoy the said demised premises for the term of this lease.
- (28) In the event that the City shall, during the period covered by this lease, obtain possession of said premises by reentry, summary proceedings, or otherwise, the Tenant hereby agrees to pay the City the expense incurred in obtaining possession of said premises, and also all expenses and commissions which may be paid in and about the letting of the same, and all other damages.
- (29) It is agreed that each and every of the rights, remedies and benefits provided by this lease shall be cumulative, and shall not be exclusive of any other of said rights, remedies and benefits, or of any other rights, remedies and benefits allowed by law.
- (30) One or more waivers of any covenant or condition by the City shall not be construed as a waiver of a further breach of the same covenant allowed by law.
- (31) Whenever under this lease a provision is made for notice of any kind it shall be deemed sufficient notice and service thereof if such notice to the Tenant is in writing addressed to the Tenant at her last known Post Office address or at the leased premises and deposited in the mail with postage prepaid and if such notice to the City is in writing addressed to the last known Post Office address of the City and deposited in the mail with postage prepaid.
- (32) The covenants, conditions and agreements made and entered into by the parties hereto are declared binding on their respective heirs, successors, representatives and assigns,
- (33) The Tenant shall maintain the premises with janitorial services and be responsible for refinishing floors at their own costs,

- (34) Tenant will provide necessary keys and alarm codes. The Tenant cannot change current locks without permission of the City, or must provide City with keys to have accessibility.
- (35) All notices, requests, demands and other communications shall be sent by certified mail, return receipt requested, with postage prepaid, to the addresses set forth below or to such other addresses as either party may designate in writing from time to time. Notice shall be effective upon deposit in United States Mail.

Notices to Tenant shall be sent to:

Rosecrans Picture Perfect
Attention: Mary
Rosecrans
12405 Pardee Rd.
Taylor, MI 48180

Notices to Landlord shall be sent to:

City of Taylor
Attention:
Mayor 23555
Goddard Rd.
Taylor, MI 48180

And with a copy to:

Attention:
Edward D. Plato
30500
Northwestern Hwy,
Suite 425
Farmington Hills,
MI 48334

IN WITNESS WHEREOF, the parties have hereunto set their hands and seals the day and year first above written.

CITY OF TAYLOR

BY: _____
Tim Woolley,
Mayor, City of Taylor

Dated: _____

MARY ROSECRANS, DBA ROSECRANS PICTURE PERFECT

BY: _____

Dated: _____

Mary Rosecrans

Witness: _____

Dated: _____

INSURANCE REQUIREMENTS:

Business Liability:

General Aggregate \$2,000,000

Products-Completed Operations \$2,000,000

Aggregate: Each Occurrence: \$1,000,000

Legal Liability Coverage: \$50,000 (each fire)

Premises Medical Payments \$10,000 (each person)

Coverage: Designation of City of Taylor

Premises: Schonscheck House
12405 Pardee Rd.
Taylor, MI 48180

International Controls & Equipment
 35083 Cordelia Clinton Twp., MI 48035
 Phone: 586-791-5400 Fax: 586-791-0903
 sales@IceGateSystems.com | www.IceGateSystems.com



Price Quote

Quote Date	Quote #
1/7/2026	79334

Customer:

City of Taylor Police
 23515 Goddard Road
 Taylor, MI 48180

Job Location:

City of Taylor Police
 23515 Goddard Road
 Taylor, MI 48180

Attention	Valid Through	Ship Via	Salesperson	Terms
Guido Ulin	3/7/2026		GG	NET Due

Qty	Description	Price	Amount
	International Controls & Equipment Proposes The Following: Wireless Emergency Open Button Communications Provide And Install 2 Wireless Relays To Activate Birch Street And Pine Street Gates From Dispatch Center Bypassing Access System And Failing In Ground Wiring ** May Be Used From Access Control Panel To Gate To Just By Pass In Ground Wire 2 Enclosures At Gate Operators To Allow For Wireless Signal 2 Verify Operation Of Switches And Operators 1 TOTAL QUOTE:	4,530.75	4,530.75
	* Any Unforeseen Additional Materials / Labor That May Be Required (Beyond Above Repairs), Will Be Quoted As "Additional Work Needed" Prior To Reactivation Of System. * Tax Exempt; Sales Tax Not Included. All material will remain the property of International Controls until all invoices pertaining to this job are paid in full. ICE retains its right or ownership, access and/or removal of said material(s) in the event of non-payment. ICE assumes no responsibility for any unmarked sprinkler lines, or any other unmarked burial lines or objects. The customer will assume all liability for damage caused by directing ICE to dig in the immediate vicinity of known utilities. ICE submits invoices via emailed PDF copies and accepts personal checks, cashier's checks, money orders and most major credit cards for payment; however, an additional 4% processing and convenience fee will be added to all Credit Card Payments. If your company requires Invoicing to be submitted through a 3rd-party platform or portal, please reach out to us immediately to confirm/approve additional administrative labor costs, that may be added to our invoice to support the billing request.		

CONDITIONS: The prices and terms outlined in this quotation are not subject to verbal change nor any other alterations unless approved in writing by the Seller. Also, the fulfillment of performance of said quotation and agreement may become invalid in time of work strikes, accident, fire, unavailability of materials or circumstances beyond our control. Typographical and stenographic errors subject to correction. Conditions not specifically stated herein shall be governed by established trade customs. TERMS INCONSISTENT WITH THOSE STATED HEREIN WHICH MAY APPEAR ON PURCHASER'S FORMAL ORDER WILL NOT BE BINDING ON THE SELLER.

TO ACCEPT THIS PROPOSAL PLEASE COMPLETE THE FOLLOWING INFORMATION AND RETURN:

PO Number: _____ Date: _____ Signature / Name: _____

**International
Controls &
Equipment**

sales@IceGateSystems.com | www.IceGateSystems.com

35083 Cordelia
Clinton Twp., MI 48035
Phone: 586-791-5400
Fax: 586-791-0903



Price Quote

Quote Date	Quote #
1/7/2026	79333

Customer:

City of Taylor Police
23515 Goddard Road
Taylor, MI 48180

Job Location:

City of Taylor Police
23515 Goddard Road
Taylor, MI 48180

Attention	Valid Through	Ship Via	Salesperson	Terms
Guido Ulin	3/7/2026		GG	NET Due

Qty	Description	Price	Amount
	International Controls & Equipment Proposes The Following: BIRCH STREET ENTRY / EXIT GATES To Change To Primary/Secondary Operation (Both Gates Opening At The Same Time) Provide And Install 1 Identify Existing Pathway And Pull Wire For Primary/Secondary Communications, And Control From Primary To Secondary Operator. * This Will Allow Both Operators To Open Simultaneously Through Access Control And Loops Allowing For A Larger Entry And Exit Opening For Vehicles. *** If Existing Pathway Is Not Usable, Wire Will Be Slot And Tucked Across Drive Between Operators *** Attempt To Pull New Wire In Existing Pathway Will Be Made After The Thaw To Give Best Chance At A Successful Wire Pull		
1	TOTAL QUOTE:	2,375.00	2,375.00
	* Any Unforeseen Additional Materials / Labor That May Be Required (Beyond Above Repairs), Will Be Quoted As "Additional Work Needed" Prior To Reactivation Of System. * Tax Exempt; Sales Tax Not Included. * Continued On Page 2		

CONDITIONS: The prices and terms outlined in this quotation are not subject to verbal change nor any other alterations unless approved in writing by the Seller. Also, the fulfillment of performance of said quotation and agreement may become invalid in time of work strikes, accident, fire, unavailability of materials or circumstances beyond our control. Typographical and stenographic errors subject to correction. Conditions not specifically stated herein shall be governed by established trade customs. TERMS INCONSISTENT WITH THOSE STATED HEREIN WHICH MAY APPEAR ON PURCHASER'S FORMAL ORDER WILL NOT BE BINDING ON THE SELLER.

TO ACCEPT THIS PROPOSAL PLEASE COMPLETE THE FOLLOWING INFORMATION AND RETURN:

PO Number: _____ Date: _____ Signature / Name: _____

TIMOTHY WOOLLEY
Mayor

CYNTHIA A. BOWER
City Clerk

MICHELLE TOCCO
City Treasurer

City of Taylor

23555 GODDARD ROAD
TAYLOR, MICHIGAN 48180

PHONE: (734) 287-6550 - www.cityoftaylor.com

CITY COUNCIL

DOUGLAS A. GEISS
Chairman

JILL BRANDANA
Chair Pro-Tem

CHARLES JOHNSON
LINDSEY ROSE
TINA DANIELS
ANGIE WINTON

SINGLE BID MEMORANDUM

To: Honorable Mayor and City Council Members

From: Guido Ulin

Date: 3/24/2025

Subject: Sole Source Supplier – Gate Repairs & Maintenance PD/City Hall

The purpose of this memorandum is to seek council approval for the attached quote from International Controls & Equipment for the repair of the two gates controlling access to the rear of City Hall, the Police Department, and the Court.

These gates have been experiencing frequent issues for several months. The original installation company, International Controls & Equipment, installed the system about five years ago and regularly services similar systems. Their familiarity with the technology makes them the best choice for diagnosing and completing the necessary repairs.

Since these gates control access for emergency response, quick resolution is essential. Delays could impact security and emergency operations.

Justification for Sole Source Procurement:

1. Expertise: International Controls & Equipment installed the system and knows it best.
2. Consistency: Using the original vendor avoids compatibility issues.
3. Urgency: Fast repairs are critical for emergency access.
4. Specialization: The company has experience servicing similar systems.

Recommendation:

I recommend that the City proceed with International Controls & Equipment as the sole source provider for these critical gate repairs. I request approval for this expenditure for inclusion on the April 1 agenda.

Respectfully,



Bid Tabulation

RFP-101425-002-Lange Park Signage

Name of Vendor	Address	Telephone	Price	Comments & Recommendations
1 Source	26600 Heyn Dr. Novi, MI 48374	812-344-1441	\$148,875.00	N/A
Blink Marketing Inc.	1925 St Clair Ave. Cleveland, OH 44114	216-503-2568	\$23,947.50	N/A
Signs by Crannie	4145 Market PL Flint, MI 48507	248-410-2678	\$51,440.16	N/A

Purchasing Agent Signature: *Julia Challeys*

Date: 01/12/2026

Time: 9:00AM

Signs By Crannie, Inc.
 4145 Market Place
 Flint, MI, 48507- USA
 Phone: (810)-487-0000 Fax: (810)-487-0711
 www.signsbycrannie.com



Proposal Submitted To:

Ben Clayton Jr.
 City of Taylor
 23555 GODDARD ROAD
 Taylor, MI 48180- USA

Phone: (734) 374-1459

Fax:

E-mail: bclayton@cityoftaylor.mi.gov

Job Name Lange Park Sign Bid

Job Name and Location

Lange Park
 14507 Lange St
 Taylor, MI 48180- USA

Proposal No	Proposal Date	Payment Terms	Contact	Page
019400	10/31/2025	Bal upon Comp.	Matthew T	Page 1 of 3

Quantity	Product - Description	Unit Price	Extended Price
1	Main Entrance sign Northline Entrance sign Eureka Entrance sign Dog Park Sign Dog Park Rules Sign Park Wayfinding interior amenities sign with 5 examples one base price qty's tbd	\$0.00	\$0.00
1	Primary Sign Locations & Requirements 1. Northline & Lange Road Intersection a. Vendor must provide multiple sizing options for this sign, along with corresponding pricing b. Must include directional arrows c. Must include City of Taylor logo d. Branding must read: "Taylor / Wayne County" 2. Eureka & Lange Road Intersection a. Same requirements as Northline & Lange b. Must include directional arrows c. Must include City of Taylor logo d. Branding must read: "Taylor / Wayne County" 3. Main Entrance to Lange Park a. Larger, more prominent sign b. Must serve as the primary park identifier c. May include additional design elements (e.g., lighting, landscaping integration) d. Must include City of Taylor/Wayne County logo and "Taylor / Wayne County" branding Wayfinding & Activity Identification Signage In addition to the three primary signs, vendors must provide options and pricing for smaller wayfinding and activity-specific signs to be placed throughout the park. These signs will serve to: • Direct visitors to key areas (e.g., trails, restrooms, parking, exits) • Identify activity zones (e.g., playgrounds, skate park, dog park, picnic areas, fishing docks) Requirements: • Durable, weather-resistant, non-wood materials • Consistent branding with primary signage • Clear, legible design with optional icons or symbols • Cost must be provided per sign, categorized by: o Directional signage o Activity/area identification signage	\$0.00	\$0.00

Proposal No	Proposal Date	Payment Terms	Contact	Page
019400	10/31/2025	Bal upon Comp.	Matthew T	Page 2 of 3

Quantity	Product - Description	Unit Price	Extended Price
----------	-----------------------	------------	----------------

Design & Material Specifications

- No wood materials are permitted for signs or posts
- All materials must be sustainable, weather-resistant, and low-maintenance
- Proposals must include:
 - o Multiple design options for each sign type
 - o Material descriptions and expected lifespan
 - o Installation method
 - o Warranty information
 - o Estimated timeline for completion

1	Dog Park 1 Signs - Double Face. 48" x 78" faces. Vinyl & digitally printed graphics. Aluminum I beam supports. Formed, chamfered concrete footing with anchor bolts for installation.	\$9,834.04	\$9,834.04
1	Dog Park 2 Signs -Double Face. 48" x 40" face. Vinyl & digitally printed graphics. Aluminum I beam supports. Formed, chamfered concrete footing with anchor bolts for installation.	\$7,969.79	\$7,969.79
1	Primary Sign 3 - Double Face. 48" x 78" faces. Vinyl & digitally printed graphics. Individual amenity panels. Aluminum I beam supports. Formed, chamfered concrete footing with anchor bolts for installation.	\$10,350.04	\$10,350.04
1	Interior Park Sign 1. Double face. Various size options (48" x 78", 48" x 96") @ 99" overall height. All aluminum construction. .125 faces with aluminum beam supports. Painted backgrounds with vinyl graphics. Printed amenity decals. Formed reinforced concrete footings per artwork.	\$10,126.54	\$10,126.54
1	Primary Sign 1. Double Face. 48" x 78" faces. Vinyl & digitally printed graphics. Aluminum I beam supports. Formed, chamfered concrete footing with anchor bolts for installation.	\$10,248.04	\$10,248.04

Proposal No	Proposal Date	Payment Terms	Contact	Page
019400	10/31/2025	Bal upon Comp.	Matthew T	Page 3 of 3

Quantity	Product - Description	Unit Price	Extended Price
----------	-----------------------	------------	----------------

PRICE QUOTATION GOOD FOR 10 DAYS.

The client is responsible for supplying production ready, vectorized artwork of logos and custom letter styles in an EPS, PDF or SVC format.

PRICES DO NOT INCLUDE PERMIT FEES OR PRIMARY ELECTRICAL TO SIGNS AND WILL BE BILLED ADDITIONALLY.

TERMS - DEPOSIT DOWN, BALANCE DUE AT TIME OF INSTALLATION.

WARRANTY - one year all parts and labor barring vandalism or acts of God.

PRICES as indicated above are minimal estimates for art or sign work only. Photostats, typography, photographs, overtime, changes and or time additions, delays caused by the client, special consultations and all other expenses that cannot be estimated accurately in advance will be billed extra unless otherwise specified herein.

FINISHED art, mechanicals, and signs will be released for use by the client only. Mechanicals, original art, sketches and materials other than signs originated by the designer are the property of the designer, and will be held for the client, unless otherwise shown.

SPECIAL conditions on the client's purchase orders in no way negate the above conditions of sale. In ordering the work described above, the client accepts these conditions whether noted on his purchase or not. IF UNUSUAL conditions (ie, access, ledge, water, rock, etc.) are encountered in the installation, this contract is binding; however, an additional cost based on our labor, plus 15% on sub-contractor and materials or equipment will be added to the above price.

THE CLIENT agrees to pay all costs of collection in the event of default of payment by the client, including a reasonable attorney's fee. In the event of delinquent payments, the client will be charged a rate of 1.5% interest for every month, after the first 30 days.

THE SIGN SHALL REMAIN THE PROPERTY of Signs by Crannie, Inc. until paid for in full. In the event the client is delinquent in payment by more than 45 days Signs by Crannie, Inc. reserves the right to remove the signage from the premise without notice of the client. And the client shall hold Signs by Crannie, Inc. free of any liability whatsoever.

Taxable	\$48,528.45
NonTaxable	\$0.00
SalesTax	\$2,911.71
Freight	\$0.00
Permits.	\$0.00
OrderTotal	\$51,440.16
Deposit Req 50%	\$25,720.08

SALESPERSON: _____ DATE: _____

ACCEPTED BY: _____ TITLE: _____

SIGNATURE: _____ DATE: _____

For: City of Taylor

DOG PARK SIGN #1

Monument Sign - Qty. 1
- Double Face, Non-Illuminated



Approx. Sign Location - NTS



SIGN TYPE

Monument Sign

SCALE

1/2"-1'-0"

COLORS

- A** Black
- B** White
- C** Green TBD
- D** PMS 476 c Brown

NOTES

Color Disclaimer: Colors displayed on screens or printed documents may appear differently than the final product. Variations can also occur due to material differences and production processes.

Design: Our estimates include the initial design and up to three revisions. Additional design work may be billed at \$90 per hour.

YES INITIALS **READY FOR PRODUCTION**

SALESPERSON

Matt Thomas

FILENAME

CityOfTaylor-LP-25-DP1

Customer / Address

City of Taylor
Lange Park

DRAWN BY / DATE

G.Alumbaugh 10-28-25



ORIGINAL ARTWORK, DESIGNS & LAYOUTS ARE THE SOLE PROPERTY OF SIGNS BY CRANNIE AND MAY NOT BE REPRODUCED, DISPLAYED, TRANSMITTED TO ANYONE, IN FULL OR IN PART WITHOUT THE WRITTEN CONSENT OF SIGNS BY CRANNIE.
©2025 Signs by Crannie



4145 Market Place
Flint, Michigan 48507
810-487-0000
www.SignsByCrannie.com

DOG PARK SIGN #2 (PARK RULES)

Monument Sign - Qty. 1
- Single Face, Non-Illuminated

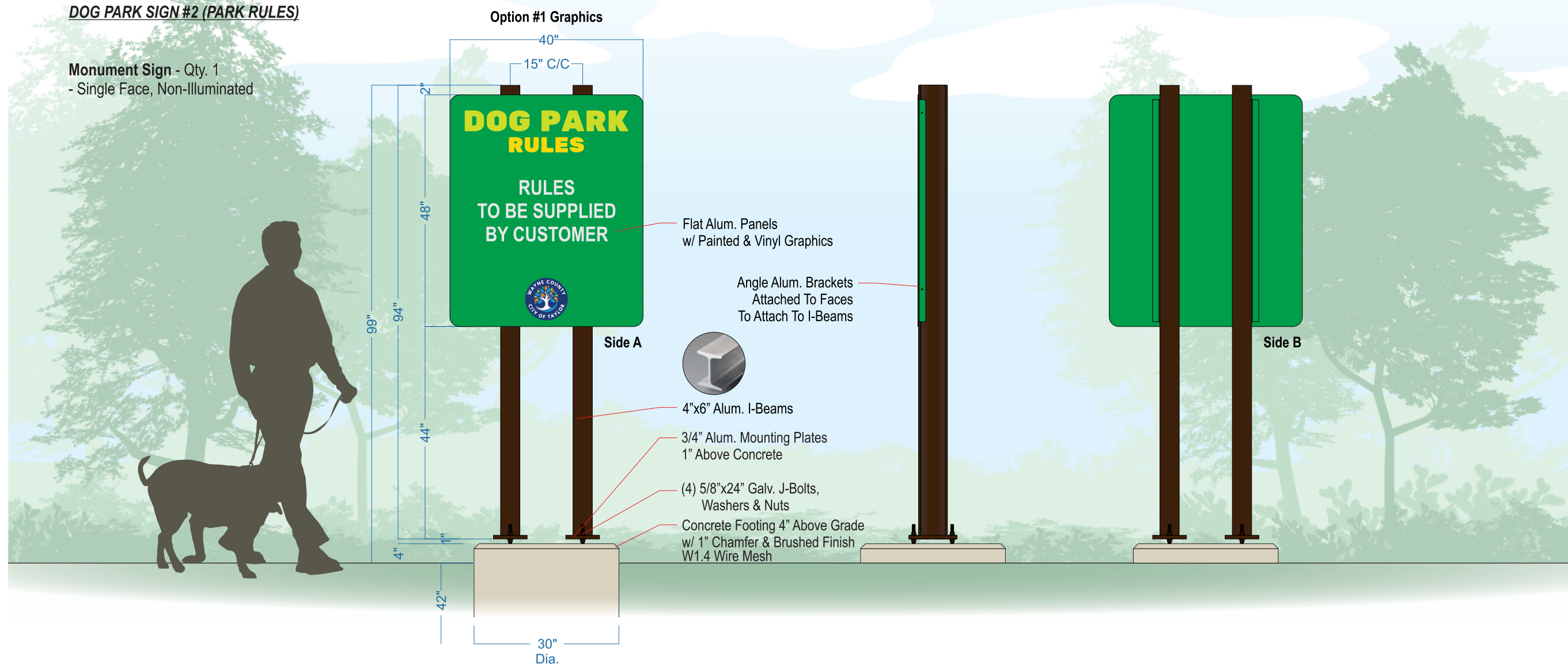

Option #2 Graphics

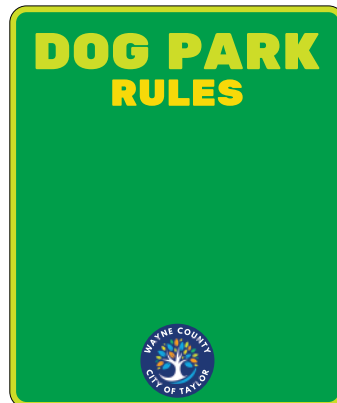

Approx. Sign Location - NTS



SIGN TYPE

Monument Sign

SCALE

1/2"-1'-0"

COLORS

- A** Black
- B** White
- C** Green TBD
- D** PMS 476 c Brown

NOTES

Color Disclaimer: Colors displayed on screens or printed documents may appear differently than the final product. Variations can also occur due to material differences and production processes.

Design: Our estimates include the initial design and up to three revisions. Additional design work may be billed at \$90 per hour.

YES INITIALS **READY FOR PRODUCTION**

SALESPERSON

Matt Thomas

FILENAME

CityOfTaylor-LP-25-DP2

Customer / Address

City of Taylor
Lange Park

DRAWN BY / DATE

G.Alumbaugh 10-28-25



ORIGINAL ARTWORK, DESIGNS & LAYOUTS ARE THE SOLE PROPERTY OF SIGNS BY CRANNIE AND MAY NOT BE REPRODUCED, DISPLAYED, TRANSMITTED TO ANYONE, IN FULL OR IN PART WITHOUT THE WRITTEN CONSENT OF SIGNS BY CRANNIE.

©2025 Signs by Crannie



4145 Market Place
Flint, Michigan 48507
810-487-0000
www.SignsByCrannie.com

INTERIOR PARK SIGN #1

Monument Sign - Qty. TBD
- Double Face, Non-Illuminated



Option #2 Graphics (48" x 78")



Option #4 Graphics (48" x 96")



Option #3 Graphics (48" x 86")



Option #5 Graphics (48" x 96")



Approx. Sign Locations - NTS

SIGN TYPE

Monument Sign

SCALE

1/2"-1'-0"

COLORS

- A** Black
- B** White
- C** Blue TBD
- D** PMS 476 c Brown

NOTES

Color Disclaimer: Colors displayed on screens or printed documents may appear differently than the final product. Variations can also occur due to material differences and production processes.

Design: Our estimates include the initial design and up to three revisions. Additional design work may be billed at \$90 per hour.

READY FOR PRODUCTION

SALESPERSON

Matt Thomas

FILENAME

CityOfTaylor-LP-25-IPS1

Customer / Address

City of Taylor
Lange Park

DRAWN BY / DATE

G.Alumbaugh 10-28-25



ORIGINAL ARTWORK, DESIGNS & LAYOUTS ARE THE SOLE PROPERTY OF SIGNS BY CRANNIE AND MAY NOT BE REPRODUCED, DISPLAYED, TRANSMITTED TO ANYONE, IN FULL OR IN PART WITHOUT THE WRITTEN CONSENT OF SIGNS BY CRANNIE.

©2025 Signs by Crannie



4145 Market Place
Flint, Michigan 48507
810-487-0000
www.SignsByCrannie.com

PARK SIGN #1
Main Entrance (North)
Lange & Northline

Monument Sign - Qty. 1
- Double Face, Non-Illuminated

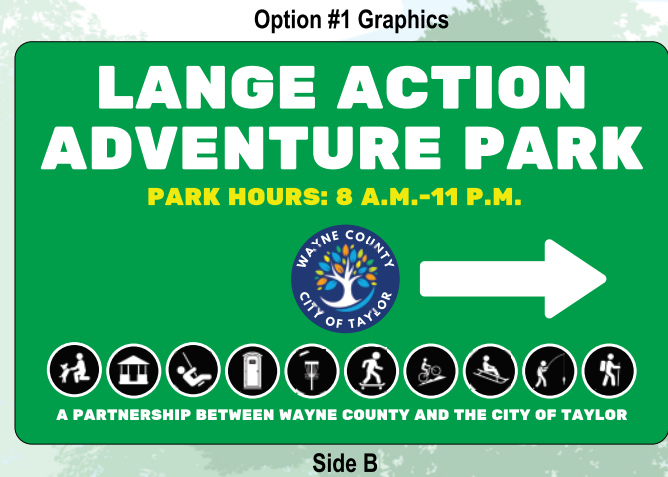
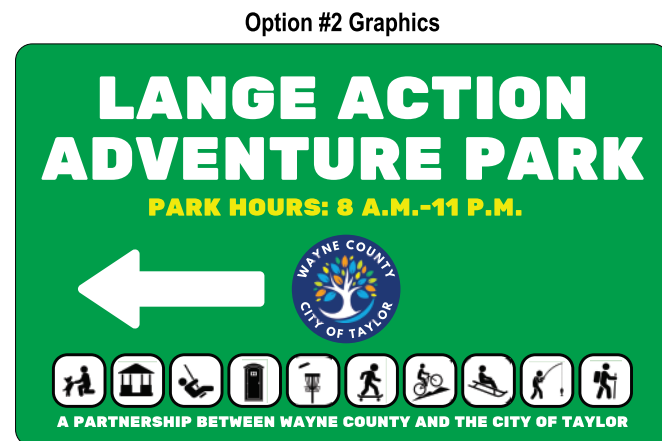
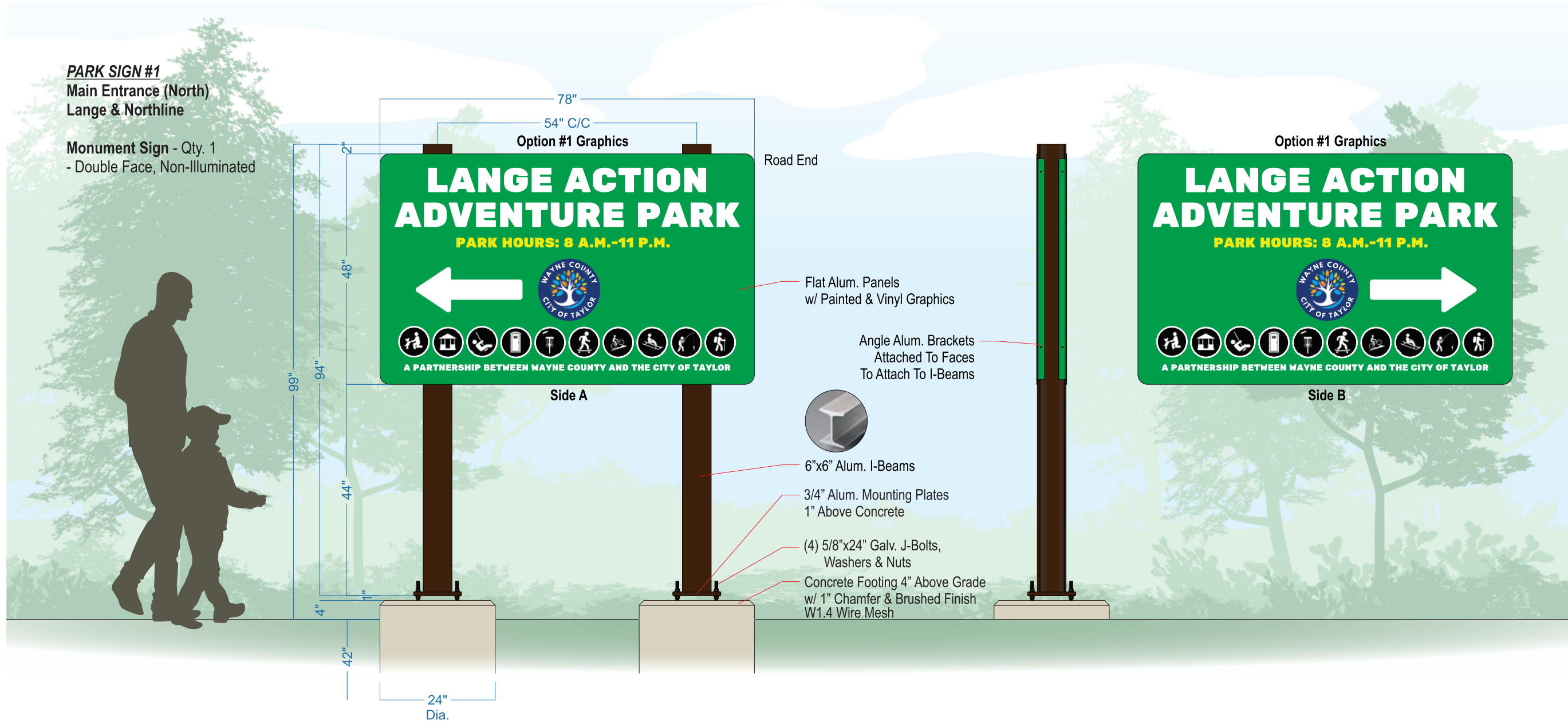

Approx. Sign Location - NTS



SIGN TYPE

Monument Sign

SCALE

1/2"-1'-0"

COLORS

- A** Black
- B** White
- C** Green TBD
- D** PMS 476 c Brown

NOTES

Color Disclaimer: Colors displayed on screens or printed documents may appear differently than the final product. Variations can also occur due to material differences and production processes.
Design: Our estimates include the initial design and up to three revisions. Additional design work may be billed at \$90 per hour.

YES INITIALS **READY FOR PRODUCTION**

SALESPERSON

Matt Thomas

FILENAME

CityOfTaylor-LP-25-PS1

Customer / Address

City of Taylor
Lange Park

DRAWN BY / DATE

G.Alumbaugh 10-28-25



ORIGINAL ARTWORK, DESIGNS & LAYOUTS ARE THE SOLE PROPERTY OF SIGNS BY CRANNIE AND MAY NOT BE REPRODUCED, DISPLAYED, TRANSMITTED TO ANYONE, IN FULL OR IN PART WITHOUT THE WRITTEN CONSENT OF SIGNS BY CRANNIE.
©2025 Signs by Crannie



4145 Market Place
Flint, Michigan 48507
810-487-0000
www.SignsByCrannie.com

PARK SIGN #2
Main Entrance (South)
Lange & Eureka

Monument Sign - Qty. 1
- Double Face, Non-Illuminated

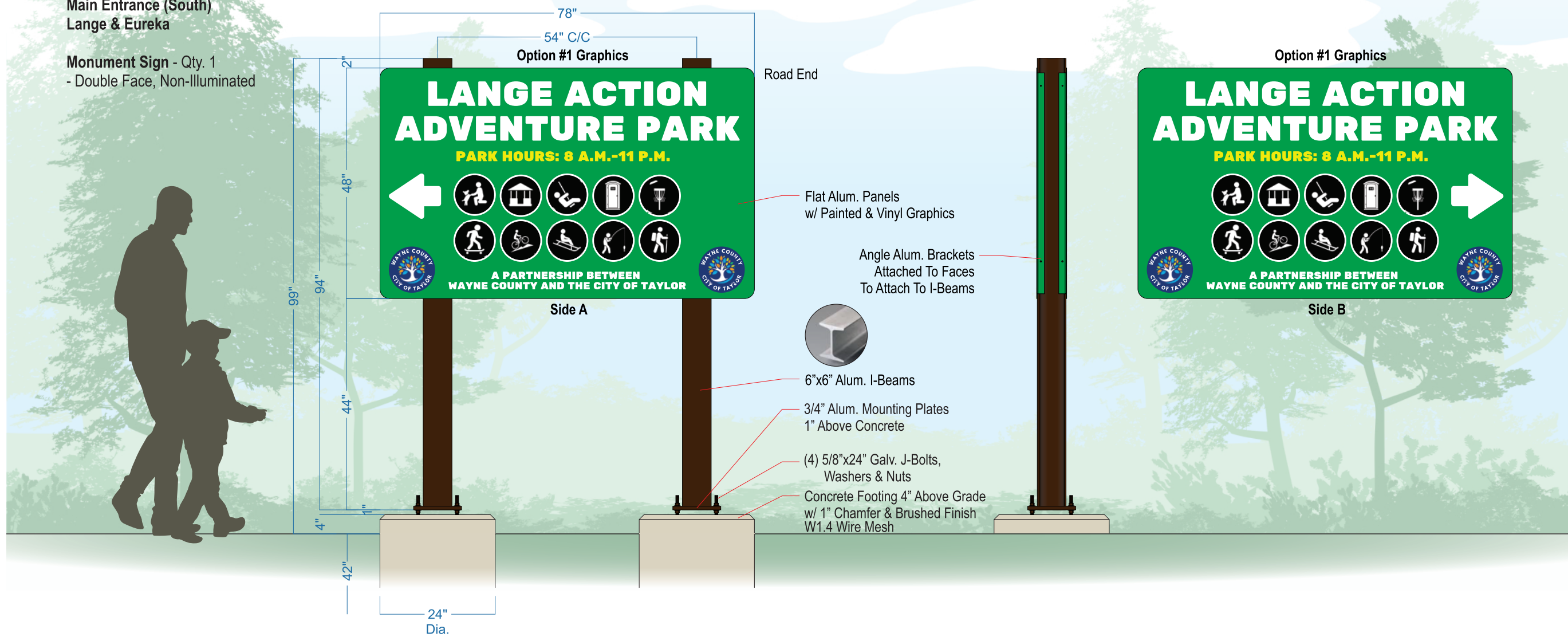

SIGN TYPE

Monument Sign

SCALE

1/2"-1'-0"

COLORS

- A** Black
- B** White
- C** Green TBD
- D** PMS 476 c Brown

NOTES

Color Disclaimer: Colors displayed on screens or printed documents may appear differently than the final product. Variations can also occur due to material differences and production processes.

Design: Our estimates include the initial design and up to three revisions. Additional design work may be billed at \$90 per hour.

READY FOR PRODUCTION

SALESPERSON

Matt Thomas

FILENAME

CityOfTaylor-LP-25-PS2

Customer / Address

City of Taylor
Lange Park

DRAWN BY / DATE

G.Alumbaugh 10-28-25



ORIGINAL ARTWORK, DESIGNS & LAYOUTS ARE THE SOLE PROPERTY OF SIGNS BY CRANNIE AND MAY NOT BE REPRODUCED, DISPLAYED, TRANSMITTED TO ANYONE, IN FULL OR IN PART WITHOUT THE WRITTEN CONSENT OF SIGNS BY CRANNIE.
©2025 Signs by Crannie



4145 Market Place
Flint, Michigan 48507
810-487-0000
www.SignsByCrannie.com

PARK SIGN #2
Main Entrance (South)
Lange & Eureka

Monument Sign - Qty. 1
- Double Face, Non-Illuminated



Flat Alum. Panels
w/ Painted & Vinyl Graphics

Angle Alum. Brackets
Attached To Faces
To Attach To I-Beams

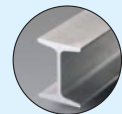

6"x6" Alum. I-Beams

3/4" Alum. Mounting Plates
1" Above Concrete

(4) 5/8"x24" Galv. J-Bolts,
Washers & Nuts

Concrete Footing 4" Above Grade
w/ 1" Chamfer & Brushed Finish
W1.4 Wire Mesh

Option #1 Graphics

Side B

Side A

Approx. Sign Location - NTS

Option #2 Graphics



SIGN TYPE

Monument Sign

SCALE

1/2"-1'-0"

COLORS

- A** Black
- B** White
- C** Green TBD
- D** PMS 476 c Brown

NOTES

Color Disclaimer: Colors displayed on screens or printed documents may appear differently than the final product. Variations can also occur due to material differences and production processes.
Design: Our estimates include the initial design and up to three revisions. Additional design work may be billed at \$90 per hour.

READY FOR PRODUCTION

SALESPERSON

Matt Thomas

FILENAME

CityOfTaylor-LP-25-PS2

Customer / Address

City of Taylor
Lange Park

DRAWN BY / DATE

G.Alumbaugh 10-28-25



ORIGINAL ARTWORK, DESIGNS & LAYOUTS ARE THE SOLE PROPERTY OF SIGNS BY CRANNIE AND MAY NOT BE REPRODUCED, DISPLAYED, TRANSMITTED TO ANYONE, IN FULL OR IN PART WITHOUT THE WRITTEN CONSENT OF SIGNS BY CRANNIE.
©2025 Signs by Crannie



4145 Market Place
Flint, Michigan 48507
810-487-0000
www.SignsByCrannie.com

PARK SIGN #3
Main Entrance
Lange

Monument Sign - Qty. 1
- Double Face, Non-Illuminated



Approx. Sign Location - NTS



SIGN TYPE

Monument Sign

SCALE

1/2"-1'-0"

COLORS

- A** Black
- B** White
- C** Green TBD
- D** PMS 476 c Brown

NOTES

Color Disclaimer: Colors displayed on screens or printed documents may appear differently than the final product. Variations can also occur due to material differences and production processes.

Design: Our estimates include the initial design and up to three revisions. Additional design work may be billed at \$90 per hour.

YES NO **READY FOR PRODUCTION**

SALESPERSON

Matt Thomas

FILENAME

CityOfTaylor-LP-25-PS3

Customer / Address

City of Taylor
Lange Park

DRAWN BY / DATE

G.Alumbaugh 10-28-25



ORIGINAL ARTWORK, DESIGNS & LAYOUTS ARE THE SOLE PROPERTY OF SIGNS BY CRANNIE AND MAY NOT BE REPRODUCED, DISPLAYED, TRANSMITTED TO ANYONE, IN FULL OR IN PART WITHOUT THE WRITTEN CONSENT OF SIGNS BY CRANNIE.
©2025 Signs by Crannie



4145 Market Place
Flint, Michigan 48507
810-487-0000
www.SignsByCrannie.com

CITY OF TAYLOR

Timothy Woolley
MAYOR

Cynthia A. Bower
CLERK

Nicone Dragone Sr.
TREASURER



23555 Goddard Road
Taylor, MI 48180
(734) 287 6550
www.cityoftaylor.com

COUNCIL

Charley Johnson
CHAIRMAN

Ron Thiede
CHAIR PRO-TEM

Christian Armstrong
Chris Clark
William Patts
Gerald P. Thomas
Dan Wallace

To: Honorable Mayor and City Council
From: Ben Clayton, Purchasing Manager
Date: 2/3/2026
Subject: Support for Agenda Item Lange Park Signage

To Whom It May Concern,

This memorandum serves to confirm that the Purchasing Department has conducted a comprehensive review of the referenced agenda item. The request has been thoroughly evaluated and is in full compliance with all applicable City of Taylor Purchasing Policies and Procedures.

This request has been vetted and complies with all applicable guidelines outlined in the City of Taylor Purchasing Policies. Accordingly, it is supported for inclusion on the February 3, 2026 City Council meeting agenda.

Best regards,

Ben Clayton Jr. MA/MPM
Purchasing Manager
City of Taylor



CITY OF TAYLOR

Treasurer's Office

23555 GODDARD
TAYLOR, MI 48180-411
(734) 287-6550
www.cityoftaylor.com

2025 Winter

TAX STATEMENT

Percent Declared as Homestead Qualified	100
Assessed Value	75,400
State Equalized Value	75,400
Taxable Value	33,292

PARCEL NUMBER

60 075 01 0139 300

15163 BEECH DALY

KB INVESTMENT, LLC
6466 HIGHVIEW ST
DEARBORN HEIGHTS, MI 48127

32D139 140 LOTS 139 AND 140
RESUB OF EUREKA LITTLE FARMS SUB
T3S R10E L50 P73 WCR

TAXING AUTHORITY		TAX AMOUNT
COUNTY	0.938200	31.23
VETERANS	0.036100	1.20
JAIL	0.927800	30.88
WC PARKS	0.242000	8.05
WCCCD	3.187600	106.12
HCMA	0.205000	6.82
DIA	0.196800	6.55
ZOO	0.098200	3.26
WCTA	0.983100	32.72
B030		1.79
WEED/GRASS ASMT		2,000.00
HAZARD ASSMT		1,486.56
TOTAL TAXES	6.814800	3,715.18
ADMINISTRATION FEE		37.15
INTEREST/PENALTY		
Amount Due		3,752.33
Amount Paid		
BALANCE DUE		3,752.33

2025 SUMMER TAXES OWING



Return Bottom Portion with Payment



CITY OF TAYLOR

Treasurer's Office

PO BOX 335
TAYLOR, MI 48180-0335
(734) 287-6550
www.cityoftaylor.com

2025 Winter

TAX STATEMENT

Percent Declared as Homestead Qualified	100
Assessed Value	75,400
State Equalized Value	75,400
Taxable Value	33,292

60 075 01 0139 300
KB INVESTMENT, LLC
6466 HIGHVIEW ST
DEARBORN HEIGHTS, MI 48127

TREASURER'S COPY		TAX AMOUNT
		3,715.18
ADMINISTRATION FEE		37.15
INTEREST/PENALTY		00.00
AMOUNT PAID		00.00
TOTAL DUE		3,752.33

See Due Dates On Reverse Side. Return This Portion With Payment.

Make Checks or Money Order Payable in US Dollars on a US Bank to City of Taylor.

For Complete Property Description See Assessment Roll at Treasurer's Office.

Write Parcel # on Check.



As Of Payoff Date: **1/20/2026**

PLEASE READ CAREFULLY

DUE DATES:

SUMMER TAXES are due and payable July 1 through September 30 without penalty. Beginning on October 1, a ?? % per month late charge will be applied and on March 1, an additional 3% late penalty will be added.

WINTER TAXES are due and payable from December 1 through February 14 without penalty.

OPERATING FISCAL YEARS

City & School: July 1 to June 30
County: December 1 to November 30

Compare the legal description with your own record of title before paying this tax.

Taxes are payable by mail or at the Taylor Treasurer's Office, online or by phone.

Detach bottom portion of tax statement and mail with your payment. Your **CANCELLED CHECK** will serve as your receipt. **PLEASE USE ENCLOSED ENVELOPE IF PAYING BY MAIL.**

If you require a printed receipt, send both copies of the Tax Statement and a self addressed stamped envelope.

PAYMENT IN PERSON: Bring in this copy of the tax statement to the Treasurer's department cashier's window, Monday through Friday, 9:00 a.m. - 5:00 p.m. Payment can also be made in the secure drop box at the Pine Street entrance to City Hall, 24 hours a day. No cash please.

Notice: If your tax bill is paid through a mortgage tax escrow account, please forward this bill immediately to your mortgage company. This is not an extra copy.

FAILURE TO RECEIVE BILL DOES NOT WAIVE PENALTY

To avoid paying in line, drop payment in the **DROP BOX on PINE STREET. NO NEED TO GET OUT OF YOUR CAR**, pull up to box and drop it in, 24 hours a day. No cash in drop box please.

DELINQUENT TAXES:

1) REAL PROPERTY TAXES: Beginning March 1, Winter and Summer delinquent taxes must be paid to :
ERIC R. SABREE, WAYNE COUNTY TREASURER,
THE INTERNATIONAL CENTER BUILDING, 400 MONROE - 5TH FLOOR, DETROIT, MICHIGAN 48226-2942.
313-224-5990. www.waynecounty.com/treasurer

2) PERSONAL PROPERTY TAXES: (APPLIES TO BUSINESS ONLY) Beginning March 1, delinquent taxes must be paid to:

CITY OF TAYLOR
PO Box 335, TAYLOR, MI
48180-4116

3) PENALTY: All delinquent tax payments on real and personal property will include a 4% penalty plus 1% interest per month.

ACCESS YOUR BILL INFORMATION ONLINE: You can look up your tax bill information by going to the City of Taylor's website at www.cityoftaylor.com. Click on "Government" (Upper left of screen) "Treasurer" "Property Tax Look Up" "Street Number ONLY" (do not put street)"Hit submit" "Choose Street Number" "Hit submit again"

Please note that the City of Taylor no longer sends an annual statement of taxes levied so please retain the top portion of your tax bill or your mortgage statement for tax information. Or you can access the information online as explained above.

For more information from the City's website, go to "Government" "Treasurer" and click on "Tax Department FAQ".

To Pay By Credit Card
Visit www.bsaonline.com.

If the tax bill is delinquent you cannot pay by credit card.

BS&A Payments, the service provider, charges a nominal fee for this service.

↓ Detach here and mail lower portion with payment ↓

City of Taylor
Treasurer's Dept.
P.O. Box 335
Taylor, MI 48180-0335

Ordinance Violation Associated View

OrdinanceID	Status	Violation Code	Street Number	Street Name	Violation Create...	Creation Date	Comments	Ordinance Inspe...	Ticket Submit D...	Tic
176472	Ticket issued	RESIDENTIAL PA...	15163	BEECH DALY	6/3/2025 7:55 AM		Vehicle on grass back yard	Isaac Villarreal	6/4/2025	Ye
176471	Ticket issued	NL/NM VEHICLE...	15163	BEECH DALY	6/3/2025 7:54 AM		Vehicle in back yard	Isaac Villarreal	6/4/2025	Ye
176470	Ticket issued	LITTER, TRASH A...	15163	BEECH DALY	6/3/2025 7:53 AM		Back yard	Isaac Villarreal	6/4/2025	Ye
176469	Ticket issued	HIGH GRASS/W...	15163	BEECH DALY	6/3/2025 7:52 AM		very high grass again	Isaac Villarreal	6/4/2025	Ye
176403	Ticket issued	BLIGHTED PROP...	15163	BEECH DALY	5/30/2025 4:09...		Property has brush, high grass, overg...	Ralph Hope	6/4/2025	Ye
176399	Ticket issued	DANGEROUS B...	15163	BEECH DALY	5/30/2025 4:01...		House has broken windows, rotted w...	Ralph Hope	6/4/2025	Ye
176033	Ticket issued	HIGH GRASS/W...	15163	BEECH DALY	5/19/2025 5:32...			Joe Kimes	5/20/2025	Ye
171525	Ticket issued	LITTER, TRASH A...	15163	BEECH DALY	11/13/2024 2:38...		TRash everywhere in front yard	Isaac Villarreal	11/14/2024	Ye
168633	Ticket issued	REGISTRATION...	15163	BEECH DALY	6/3/2024 10:21...		No registration	Shawn Donovan	6/3/2024	Ye
168632	Ticket issued	CERTIFICATE OF...	15163	BEECH DALY	6/3/2024 10:20...		Resident says he is a new tenant here.	Shawn Donovan	6/3/2024	Ye
168630	Ticket issued	HIGH GRASS/W...	15163	BEECH DALY	6/3/2024 10:19...		Rear grass high in rear. 3ft tall	Shawn Donovan	6/3/2024	Ye
168444	Ticket issued	LITTER, TRASH A...	15163	BEECH DALY	5/24/2024 11:01...		Order clean up per Lanny.	Shawn Donovan	5/24/2024	Ye
168186	Ticket issued	HIGH GRASS/W...	15163	BEECH DALY	5/14/2024 6:09...		Grass is high	Shawn Donovan	5/22/2024	Ye
162309	Ticket issued	DEAD, DISEASE...	15163	BEECH DALY	6/29/2023 10:25...		Rear yard	Shawn Donovan	7/3/2023	Ye
162308	Ticket issued	LITTER, TRASH A...	15163	BEECH DALY	6/29/2023 10:24...		Backyard full of trash. Tires, etc.	Shawn Donovan	7/3/2023	Ye
162307	Ticket issued	HIGH GRASS/W...	15163	BEECH DALY	6/29/2023 10:23...		4th ticket of the year. Grass is 3-4 ft t...	Shawn Donovan	7/3/2023	Ye
161690	Ticket issued	NL/NM VEHICLE...	15163	BEECH DALY	6/7/2023 9:03 AM		Truck with expired tag.	Shawn Donovan	6/7/2023	Ye
161689	Ticket issued	LITTER, TRASH A...	15163	BEECH DALY	6/7/2023 9:02 AM		Still here.	Shawn Donovan	6/7/2023	Ye
161645	Ticket issued	HIGH GRASS/W...	15163	BEECH DALY	6/5/2023 6:34 PM		Grass still high	Shawn Donovan	6/7/2023	Ye
161464	Ticket issued	HIGH GRASS/W...	15163	BEECH DALY	5/30/2023 9:21...		Backyard 3 ft tall, up to the height of...	Shawn Donovan	5/30/2023	Ye
160813	Ticket issued	LITTER, TRASH A...	15163	BEECH DALY	5/9/2023 11:54...		Old arcade machines piled up near g...	Shawn Donovan	5/19/2023	Ye
160812	Ticket issued	HIGH GRASS/W...	15163	BEECH DALY	5/9/2023 11:54...		Grass is high	Shawn Donovan	5/19/2023	Ye
159990	Ticket issued	TIME FOR PLACL...	15163	BEECH DALY	4/4/2023 3:15 PM		Cans in front yard	Isaac Villarreal	4/25/2023	Ye
159989	Ticket issued	LITTER, TRASH A...	15163	BEECH DALY	4/4/2023 3:13 PM		Trash on porch,tires by fence	Isaac Villarreal	4/25/2023	Ye
155513	Resolved	LITTER, TRASH A...	15163	BEECH DALY	7/27/2022 2:40...		Recheck per Matt Zick, for court. 3 w...	Shawn Donovan		Nc
154512	Ticket issued	TIME FOR PLACL...	15163	BEECH DALY	6/20/2022 3:19...		A good amount of loose trash at cur...	Shawn Donovan	6/21/2022	Ye
154509	Ticket issued	LITTER, TRASH A...	15163	BEECH DALY	6/20/2022 3:16...		Yard a mess. Litter and scrap everyw...	Shawn Donovan	6/21/2022	Ye
154460	Resolved	EXTERIOR STRU...	15163	BEECH DALY	6/20/2022 9:51...		Porch needs repair	Isaac Villarreal		Nc
154459	Resolved	TIME FOR PLACL...	15163	BEECH DALY	6/20/2022 9:50...		LTR not trash day	Isaac Villarreal		Nc
154458	Resolved	LITTER, TRASH A...	15163	BEECH DALY	6/20/2022 9:49...		Front yard	Isaac Villarreal		Nc
154457	Resolved	BLIGHTED PROP...	15163	BEECH DALY	6/20/2022 9:48...		LTR in front yard	Isaac Villarreal		Nc
154456	Resolved	LITTER, TRASH A...	15163	BEECH DALY	6/20/2022 9:48...		front yard	Isaac Villarreal		Nc
152065	Ticket issued	RESIDENTIAL PA...	15163	BEECH DALY	3/7/2022 11:08...		Truck parked on grass	Robert Grimm	3/8/2022	Ye
152064	Ticket issued	STORAGE OF RE...	15163	BEECH DALY	3/7/2022 11:08...		Boat parked on grass in front of fence	Robert Grimm	3/8/2022	Ye
152063	Ticket issued	LITTER, TRASH A...	15163	BEECH DALY	3/7/2022 11:07...		Appliances, litter, debris in driveway...	Robert Grimm	3/8/2022	Ye
152062	Resolved	CULVERTS, DRAI...	15163	BEECH DALY	3/7/2022 11:02...		litter and debris in ditch to be cleaned	Vince Alessandrini		Nc
151028	Ticket issued	LITTER, TRASH A...	15163	BEECH DALY	1/3/2022 1:54 PM		Debris in driveway	Robert Grimm	1/20/2022	Ye
147300	Ticket issued	LITTER, TRASH A...	15163	BEECH DALY	8/11/2021 1:31...		Rear ysrd	Shawn Donovan	8/23/2021	Ye
142840	Resolved	INFORMATIONAL	15163	BEECH DALY	5/4/2021 11:40...		Recheck on tickets issued per officer...	Isaac Villarreal		Nc
141519	Ticket issued	LITTER, TRASH A...	15163	BEECH DALY	3/23/2021 9:54...		Trash in rear and front	Shawn Donovan	3/25/2021	Ye
124019	Resolved	HIGH GRASS/W...	15163	BEECH DALY	6/19/2019 10:36...		High Grass/Weeds - OCCUPIED HOM...	Isaac Villarreal		Nc
119014	Resolved	LITTER, TRASH A...	15163	BEECH DALY	3/1/2019 1:52 PM			Sean McGuckin		Nc
109404	Ticket issued	HIGH GRASS/W...	15163	BEECH DALY	6/3/2018 2:45 PM		Observed high grass Section 23. Back...	Shawn Donovan	6/4/2018	Ye
98566	Resolved	HIGH GRASS/W...	15163	BEECH DALY	5/31/2017 12:01...			Sean McGuckin		Nc
75614	Ticket issued	JUNK and DEBRIS	15163	BEECH DALY	8/18/2016 9:43...	1/28/2016 12:00...		Shawn Donovan		Nc
47384	Resolved	NL/NM VEHICLE...	15163	BEECH DALY	8/18/2016 7:38...	9/20/2010 12:00...		TANNIA JETT		Nc
47385	Resolved	ACCESSORY STR...	15163	BEECH DALY	8/18/2016 7:38...	9/20/2010 12:00...		TANNIA JETT		Nc
35117	Inactive	NL/NM VEHICLE...	15163	BEECH DALY	8/18/2016 6:55...	12/8/2007 12:00...		John Carter		Nc

Transaction Inquiry-----UT7010S1-----

Account#: 750140 18391 Current Balance . : 85.78

Name . : OCCUPANT

Address : 15163 BEECH DALY

Type options, press Enter. Reset: _____

5=Detail 6=Reprint Bill 11=Meter History 16=Other Charges

More: +

Opt	Type	Date	Amount	Posted	Due Date	Balance
__	Bill	1/03/2026	46.59	1/20/2026	1/31/2026	85.78
__	Penalty	12/10/2025	3.56	12/10/2025		39.19
__	Payment	11/06/2025	6461.54-	11/07/2025		35.63
__	Bill	11/07/2025	35.63	11/06/2025	12/05/2025	6497.17
__	Penalty	10/17/2025	1.06	10/17/2025		6461.54
__	Bill	9/13/2025	10.63	9/11/2025	10/11/2025	6460.48
__	Penalty	8/26/2025	1.06	8/26/2025		6449.85
__	Bill	7/11/2025	10.63	7/10/2025	8/08/2025	6448.79
__	Penalty	6/19/2025	95.86	6/19/2025		6438.16
__	Bill	5/09/2025	958.70	5/07/2025	6/06/2025	6342.30
						More...

F3=Exit , , F5=Acct , , F9=Tran Date , , F11=View 2 , , F12=Cancel , , F19=Aging-----

STATE OF MICHIGAN

BILL SCHUETTE, ATTORNEY GENERAL

REVENUE BOND ACT:

Municipal collection of delinquent utility-service charges on tax foreclosed property

GENERAL PROPERTY TAX ACT:

A municipality cannot require purchasers of tax foreclosed property to pay delinquent utility-service charges incurred by former owners of the foreclosed property before the municipality will provide utility services to the new owners of the property. Under the General Property Tax Act, MCL 211.1 *et seq.*, a judgment of foreclosure extinguishes all liens and interests related to unpaid utility-service charges against the property. MCL 211.78k. A municipality may, however, seek to recover such charges by including the delinquent charges in the cost of the property at the time it is offered for sale under the General Property Tax Act, or by instituting other lawful action against the former owners.

Opinion No. 7258

May 6, 2011

Honorable Paul E. Opsommer
State Representative
The Capitol
Lansing, MI 48909

You have asked whether a municipality may require purchasers of tax foreclosed property to pay delinquent utility-service charges incurred by former owners of the foreclosed property before the municipality will provide utility services to the new owners. In particular, you ask about water and sewage charges, as well as charges for electrical service from a municipally-owned power plant.

Information provided to this office indicates the municipality relies on 1939 PA 178 as amended, MCL 123.161 *et seq.*, and section 21 of the Revenue Bond Act of 1933, MCL 141.121, as the bases for refusing to provide utility service to new owners of tax foreclosed properties that have delinquent utility charges.

The first statute, 1939 PA 178, addresses water and sewage services. Section 2, MCL 123.162, provides that a municipality supplying water or sewage services has a lien on the premises served, as security for the collection of water or sewage system rates or charges. "This lien shall become effective immediately upon the distribution of the water or provision of the sewage system service to the premises or property supplied, but shall not be enforceable for more than 3 years after it becomes effective." Section 3, MCL 123.163, provides that the lien may be enforced "in the manner prescribed in the charter of the municipality, by the general laws of the state providing for the enforcement of tax liens, or by an ordinance duly passed by the governing

body of the municipality." Section 5, MCL 123.165, provides that the lien has priority over all other liens except taxes or special assessments:

The lien created by this act shall . . . have priority over all other liens *except taxes or special assessments* whether or not the other liens accrued or were recorded before the accrual of the water or sewage system lien created by this act. [Emphasis added.]

Section 6, MCL 123.166, provides that a municipality may enforce its liens by discontinuing water or sewer services:

A municipality may discontinue water service or sewage system service from the premises against which the lien created by this act has accrued if a person fails to pay the rates, assessments, charges, or rentals for the respective service, or may institute an action for the collection of the same in any court of competent jurisdiction. However, a municipality's attempt to collect these sewage system or water rates, assessments, charges, or rentals by any process shall not invalidate or waive the lien upon the premises.

The second statute on which the municipality relies, the Revenue Bond Act of 1933, MCL 141.101 *et seq.*, includes facilities for water, sewer, and electrical services within the definition of "public improvements" covered by the Act. MCL 141.103(b). Under section 21(3), MCL 141.121(3), a municipality may assert a lien for unpaid water, sewer, and electrical service charges. This section further provides for enforcement of the lien by collection in the same manner as taxes are collected, or by discontinuing service to the premises:

Charges for services furnished to a premises may be a lien on the premises, and those charges delinquent for 6 months or more may be certified annually to the proper tax assessing officer or agency who shall enter the lien on the next tax roll against the premises to which the services shall have been rendered, and the charges *shall be collected and the lien shall be enforced in the same manner as provided for the collection of taxes assessed upon the roll and the enforcement of the lien for the taxes.* . . . In addition to any other lawful enforcement methods, the payment of charges for water service to any premises *may be enforced by discontinuing the water service* to the premises and the payment of charges for sewage disposal service or storm water disposal service to a premises may be enforced by discontinuing the water service, the sewage disposal service, or the storm water disposal service to the premises, or any combination of the services. [MCL 141.123(3) (emphasis added).]

In summary, 1939 PA 178 and the Revenue Bond Act provide that unpaid utility-service charges become liens against the property that may be enforced by discontinuing services, instituting a collection action, or entering the lien on the tax roll against the property. These statutes, however, must be read in conjunction with the foreclosure provisions of the General Property Tax Act (GPTA), MCL 211.1 *et seq.*

Delinquent property taxes are subject to forfeiture and foreclosure under sections 78 through 78o of the GPTA, MCL 211.78 – 211.78o. On March 1 each year, taxes levied in the immediately preceding year that remain unpaid are returned delinquent to the county treasurer. MCL 211.78a(2). On March 1 of the year following delinquency, if the delinquent taxes remain

unpaid, the property forfeits to the county treasurer. MCL 211.78g(1).¹ If taxes remain unpaid, a circuit court will hold a foreclosure hearing within 30 days before March 1 of the year following forfeiture, followed by a final redemption period that expires on March 31, the effective date of the foreclosure judgment. MCL 211.78h(5) and 211.78k.² For example, unpaid 2010 taxes are returned delinquent to the county treasurer on March 1, 2011, forfeited to the county treasurer on March 1, 2012, and foreclosed on March 31, 2013.

In adopting the current tax foreclosure process in 1999 PA 123, the Legislature made clear its desire to promote the return of tax-delinquent property to productive use:

The legislature finds that there exists in this state a continuing need to strengthen and revitalize the economy of this state and its municipalities by encouraging the efficient and expeditious return to productive use of property returned for delinquent taxes. Therefore, the powers granted in this act relating to the return of property for delinquent taxes constitute the performance by this state or a political subdivision of this state of essential public purposes and functions. [MCL 211.78(1) (emphasis added).]

To promote the return of tax-delinquent property to productive use, the Legislature provided in section 78k(5) of the GPTA that, with narrow exceptions not relevant here, all liens against property and other interests in property, recorded or unrecorded, are canceled when the tax-delinquent property is foreclosed:

The circuit court's [foreclosure] judgment shall specify all of the following:

* * *

(c) *That all liens against the property, including any lien for unpaid taxes or special assessments, except future installments of special assessments and liens recorded by this state or the foreclosing governmental unit pursuant to the natural resources and environmental protection act . . . , are extinguished, if all forfeited delinquent taxes, interest, penalties, and fees are not paid on or before the March 31 immediately succeeding the entry of a judgment foreclosing the property under this section*

(d) *That, except as otherwise provided in subdivisions (c) and (e), the foreclosing governmental unit has good and marketable fee simple title to the property, if all forfeited delinquent taxes, interest, penalties, and fees are not paid on or before the March 31 immediately succeeding the entry of a judgment foreclosing the property under this section*

(e) *That all existing recorded and unrecorded interests in that property are extinguished, except a visible or recorded easement or right-of-way, private deed restrictions, interests of a lessee or an assignee of an interest of a lessee under a recorded oil or gas lease, interests in oil or gas in that property that are owned by a person other than the owner of the surface that have been preserved as provided in section 1(3) of 1963 PA 42 . . . , or restrictions or other governmental interests imposed pursuant to the natural resources and environmental protection act . . . , if all forfeited delinquent taxes, interest, penalties, and fees are not paid on or before the March 31 immediately succeeding the entry of a judgment foreclosing the property under this section [MCL 211.78k(5) (emphasis added).]*

Liens for unpaid utility-service charges do not fall within the narrow interests excepted from extinguishment under this statute.

The Legislature reiterated its intent that utility liens on tax foreclosed properties be canceled when it added section 78m(13) to the GPTA in 2003 PA 263, cancelling certain liens that may arise during or immediately following the foreclosure process:

For property sold under this section . . . , all liens for costs of demolition, safety repairs, debris removal, or sewer or water charges due on the property as of the December 31 immediately succeeding the sale . . . of the property are canceled effective on that December 31. [MCL 211.78m(13).]

Tax foreclosure cancels any liens against property for water or sewage services imposed under 1939 PA 178, relied on by the municipality, because: (1) section 5 of 1939 PA 178, MCL 123.165, expressly provides that liens under the act are junior to tax liens on the property; (2) the express language of the foreclosure judgment as set forth in section 78k(5) of the GPTA, MCL 211.78k(5), cancels the liens against foreclosed property; and (3) the express language of section 78m(13) of the GPTA, MCL 211.78m(13), cancels any subsequent lien due on property that may arise during the year of the foreclosure of the property. Although section 6 of 1939 PA 178, MCL 123.166, authorizes a municipality to enforce its liens by discontinuing service, once the tax liens are foreclosed no liens remain against the property that can be enforced by refusing to provide service. Accordingly, 1939 PA 178 does not authorize a municipality to refuse utility services to tax foreclosed property based on unpaid charges incurred by former owners.

Similarly, pursuant to sections 78k(5) and 78m(13) of the GPTA, MCL 211.78k(5) and 211.78m(13), tax foreclosure cancels liens against property imposed under the Revenue Bond Act of 1933, also relied on by the municipality. It is true that section 21 of the Revenue Bond Act provides for the enforcement of charges for water and sewer services in language that is not directly tied to the existence of a lien against the property:

In addition to any other lawful enforcement methods, the payment of charges for water service to any premises may be enforced by discontinuing the water service to the premises and the payment of charges for sewage disposal service or storm water disposal service to a premises may be enforced by discontinuing the water service, the sewage disposal service, or the storm water disposal service to the premises, or any combination of the services. [MCL 141.121.]

But, to the extent this enforcement mechanism is an interest in the property that runs with the land, section 78k(5)(e) of the GPTA, MCL 211.78k(5)(e), cancels that interest by extinguishing "all existing recorded and unrecorded interests in [foreclosed] property." Conversely, if the enforcement mechanism is not an interest that runs with the land, it is not enforceable against the new owner, assuming the new owner is not contractually bound to pay a prior owner's indebtedness and has not received any service for which payment is due. Accordingly, the Revenue Bond Act of 1933 does not provide a basis on which a municipality can refuse to provide utility services to tax foreclosed property based on unpaid charges incurred by former owners.

The tax foreclosure's extinguishment of liens against foreclosed property for unpaid utility services provided to former owners does not necessarily extinguish the debt, merely the enforcement mechanisms that would run with the land to new owners acquiring through or after the tax foreclosure. Thus, municipalities are free to pursue other lawful collection mechanisms against the former owners.

It should also be noted, as set out above, that both 1939 PA 178 and the Revenue Bond Act of 1933 provide that liens for service charges can be enforced in the same manner as provided for the collection of delinquent taxes. Thus, if the local ordinances authorize the collection of service charges as taxes and the municipality places delinquent utility charges on the tax roll, the delinquent charges can be included in the minimum bid at which foreclosed property is offered for sale under section 78m of the GPTA. MCL 211.78m. If this is done, and sale proceeds are sufficient, the utility charges would be recovered out of sale proceeds under section 78m(8)(a) of the GPTA. MCL 211.78m(8)(a).

It is my opinion, therefore, that a municipality cannot require purchasers of tax foreclosed property to pay delinquent utility-service charges incurred by former owners of the foreclosed property before the municipality will provide utility services to the new owners of the property. Under the General Property Tax Act, MCL 211.1 *et seq.*, a judgment of foreclosure extinguishes all liens and interests related to unpaid utility-service charges against the property. MCL 211.78k. A municipality may, however, seek to recover such charges by including the delinquent charges in the cost of the property at the time it is offered for sale under the General Property Tax Act, or by instituting other lawful action against the former owners.

BILL SCHUETTE
Attorney General

¹ "Forfeiture" means only that a foreclosing governmental unit may seek a judgment of foreclosure if property is not redeemed as provided under the Act. MCL 211.78(7)(b). Forfeiture does not affect title per se. Forfeiture does not give the county treasurer or the State (if the State is the foreclosing governmental unit), any right, title, or interest in the property. *Id.*

² Contested foreclosures may be decided at a later hearing, in which case the redemption period expires 21 days after entry of the foreclosure judgment on the contested parcel. MCL 211.78k(5).

Taylor City Council
23555 Goddard Road
Taylor, Michigan 48180

Subject: Knights of Columbus Annual Tootsie Roll Drive Palm Sunday weekend March 27 - 29, 2026.

All Saints Council #4872 of Taylor is requesting your permission to place our Knights, members of their families and friends on city intersections and store fronts in Taylor. We will also be soliciting our member Churches of St Alfred and St. Constance. Local councils all over the state and our country choose this special weekend before Easter for our worthwhile endeavor. The funds collected will support the physically and mentally impaired children in Taylor, Downriver, and the State of Michigan. A couple of the charities we supported in Taylor last year were the Penrickton Center for blind and handicapped children and the Taylor School District POHI program for physically or otherwise health impaired students. Soliciting will exclude those intersections prohibited by the city.

Soliciting will take place during daylight hours only by adults who are at least 18 years old. Bright colored K of C vests will be worn and coin canisters used for collection will show the name All Saints K of C Council #4872.

All people participating will be covered by insurance through the State Council of the Knights of Columbus.

Thank you for your support this year and in past years. The special needs children of Taylor and the surrounding Downriver communities will benefit greatly from this worthy cause.

Sincerely,

Dan Bzura
All Saints Knights of Columbus Council #4872
24900 Brest Road
Taylor, MI 48180